



FX3U-4AD-ADP USER'S MANUAL

Manual Number	JY997D13901
Revision	C
Date	June 2005

This manual describes the part names, dimensions, mounting, and specifications of the product. Before use, read this manual and manuals of relevant products fully to acquire proficiency in handling and operating the product. Make sure to learn all the product information, safety information, and precautions. And, store this manual in a safe place so that you can take it out and read it whenever necessary. Always forward it to the end user. Registration The company name and the product name to be described in this manual are the registered trademarks or trademarks of each company. Effective June 2005 Specifications are subject to change without notice. © 2005 Mitsubishi Electric Corporation

Safety Precaution (Read these precautions before use.) This manual classify the safety precautions into two categories:

⚠ DANGER	Indicates that incorrect handling may cause hazardous conditions, resulting in death or severe injury.
⚠ CAUTION	Indicates that incorrect handling may cause hazardous conditions, resulting in medium or slight personal injury or physical damage.

Depending on circumstances, procedures indicated by **⚠ CAUTION** may also be linked to serious results. In any case, it is important to follow the directions for usage.

Associated Manuals

Manual name	Manual No.	Description
FX3U / FX3UC Series User's Manual - Analog Control Edition	JY997D16701 MODEL CODE: 09R619	Describes specifications for analog control and programming method for FX3U / FX3UC Series PLC.
FX3U/FX3UC Series Programming Manual - Basic & Applied Instruction Edition	JY997D16601 MODEL CODE: 09R517	Describes PLC programming for basic/applied instructions and devices.
FX3U Series User's Manual - Hardware Edition	JY997D16501 MODEL CODE: 09R516	Explains FX3U Series PLC specification details for I/O, wiring, installation, and maintenance.

Note: FX3UC Series PLC specification details for I/O, wiring, installation, and maintenance can only be found in the Japanese Manual.

How to obtain manuals
For the necessary product manuals or documents, consult with the Mitsubishi Electric dealer from where you purchase your product.

Applicable Standard
FX3U-4AD-ADP made in June, 2005 or later complies with the EC Directive (EMC Directive) and UL standards (UL, cUL). Further information can be found in the following manual. However, FX3UC-32MT-LT does not comply with EC Directive (EMC Directive), UL standards (UL, cUL).
→ Refer to FX3U Series Hardware Manual (Manual No. JY997D18801)

Caution for EC Directive
The analog special adapters have been found to be compliant to the European standards in the aforesaid manual and directive. However, for the very best performance from what are in fact delicate measuring and controlled output device Mitsubishi Electric would like to make the following points:
As analog devices are sensitive by nature, their use should be considered carefully. For users of proprietary cables (integral with sensors or actuators), these users should follow those manufacturers installation requirements. Mitsubishi Electric recommend that shielded cables should be used. If NO other EMC protection is provided, then users may experience temporary induced errors not exceeding +10%/-10% in very heavy industrial areas. However, Mitsubishi Electric suggest that if adequate EMC precautions are followed with general good EMC practice for the users complete control system, users should expect normal errors as specified in this manual.
• Sensitive analog cable should not be laid in the same trunking or cable conduit as high voltage cabling. Where possible users should run analog cables separately.
• Good cable shielding should be used. When terminating the shield at Earth - ensure that no earth loops are accidentally created.
• When reading analog values, EMC induced errors can be smoothed out by averaging the readings. This can be achieved either through functions on the analog special adapters or through a users program in the FX3U Series PLC main unit.

1. Outline
The FX3U-4AD-ADP adapter for analog input (hereinafter called 4AD-ADP) is a special adapter to add four analog input points.

1.1 Incorporated Items
Check if the following product and items are included in the package:

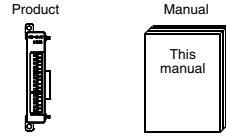

1.2 External Dimensions, Part Names, and Terminal Layout

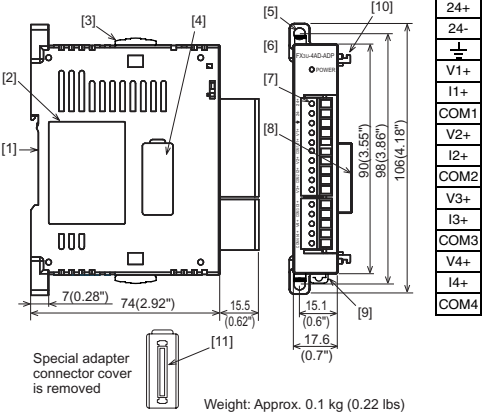

- [1] DIN rail mounting groove (DIN rail: DIN46277)
- [2] Name plate
- [3] Special adapter slide lock: Used to connect special adapter on left side of this special adapter.
- [4] Special adapter connector cover: Remove this cover for connecting special adapter on the left side.
- [5] Direct mounting hole: 2 holes of φ4.5 (0.18") (mounting screw: M4 screw) Not used when connecting to FX3UC Series PLC.

- [6] POWER LED (green): Lit while 24V DC power is supplied properly to terminals '24-' and '24+'.
- [7] Terminal block (European type): Connect the analog voltage/current signal, and 24V DC power supply.
- [8] Special adapter connector: Used to connect this special adapter to PLC main unit or special adapter.
- [9] DIN rail mounting hook
- [10] Special adapter fixing hook
- [11] Special adapter connector: Used to connect communication special adapter or analog special adapter to this adapter on left side.

2. Installation
The product can be mounted on a DIN rail (DIN46227) or mounted directly using screws.
For installation/uninstallation and safety precautions, refer to the following manuals:
→ Refer to the FX3U Series User's Manual - Hardware Edition.

INSTALLATION PRECAUTIONS **⚠ DANGER**

- Cut off all phases of the power source externally before starting the installation or wiring work, thus avoiding electric shock or damages to the product.

INSTALLATION PRECAUTIONS **⚠ CAUTION**

- Use the product in the environment within the general specifications described in PLC main unit manual (Hardware Edition). Never use the product in areas with dust, oily smoke, conductive dusts, corrosive gas (salt air, Cl₂, H₂S, NH₃, SO₂, or NO₂), flammable gas, vibrations or impacts, or expose it to high temperature, condensation, or wind and rain. If the product is used in such a place described above, electrical shock, fire, malfunction, damage, or deterioration may be caused.
- When drilling screw holes or wiring, cutting chips or wire chips should not enter ventilation slits. Such an accident may cause fire, failure or malfunction.
- Do not touch the conductive parts of the product directly, thus avoiding failure or malfunction.
- Fix the special adapter securely to the specified connector. Incorrect connection may cause malfunction.

2.1 Connection to the FX3U Series PLC

- Refer to the procedure 2) for configuring a new system.
- Refer to the procedure 1) for adding product to an existing system.

Procedure
1) Turn off the power. Disconnect all the cables connected to the PLC main unit and special adapter. Dismount the main unit and special adapter mounted on DIN rail or mounted directly using screws.
2) Install an expansion board to the main unit. For installation of expansion board, refer to the following manual:
→ Refer to the FX3U Series User's Manual - Hardware Edition
3) Remove the special adapter connector cover on the expansion board (Right fig.A). In case of connecting this product to another special adapter, please replace the 'expansion board' in the above description with a 'special adapter' and perform the procedure as indicated.
4) Slide the special adapter slide lock (Right fig.B) of the main unit. In case of connecting this product to another special adapter, please replace the 'main unit' in the above description with a 'special adapter' and perform the procedure as indicated. (Please replace the following procedures similarly.)

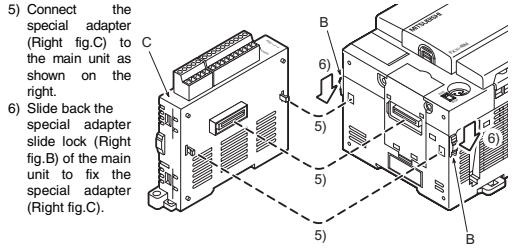
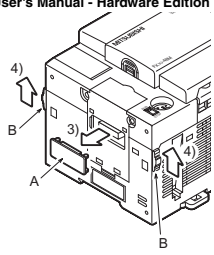

Connection precautions
Connect all the high-speed I/O special adapters before connecting other special adapters when they are used in combination. Do not connect a high-speed I/O special adapter on the left side of a communication or analog special adapter.

2.2 Connection to the FX3UC Series PLC

- Refer to the procedure 2) for configuring a new system.
- Refer to the procedure 1) for adding product to an existing system.

Procedure
1) Turn off the power. Disconnect all the cables connected to the PLC. Dismount the PLC from the DIN rail.
2) Install an expansion board to the main unit. For installation of expansion board, refer to the following manual:
→ Refer to the manual of the expansion board to be used.

3) Remove the special adapter connector cover on the expansion board (Right fig.A). In case of connecting this product to another special adapter, please replace the 'expansion board' in the above description with a 'special adapter' and perform the procedure as indicated.
4) Slide the special adapter slide lock (Right fig.B) of the main unit. In case of connecting this product to another special adapter, please replace the 'main unit' in the above description with 'special adapter' and perform the procedure as indicated. (Please replace the following procedures similarly.)

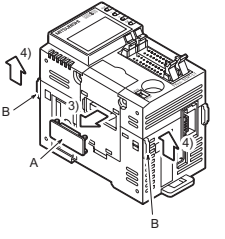

5) Connect special adapter (Right fig.C) to the main unit as shown on the right.
6) Slide back the special adapter slide lock (Right fig.B) of the main unit to fix the special adapter (Right fig.C).

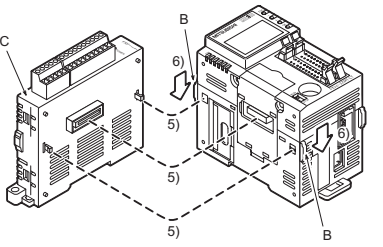

3. Wiring

WIRING PRECAUTIONS **⚠ DANGER**

- Cut off all phases of power source externally, before installation or wiring work in order to avoid electric shock or damage of product.

WIRING PRECAUTIONS **⚠ CAUTION**

- Never let cutting chips and wire chips enter the ventilation slits of this product or PLC when performing wiring. Otherwise, fire, failure or malfunction may occur.
- Make sure to observe the precautions below in order to prevent any damage to a machine or any accident which might be caused by abnormal data written in the PLC due to the influence of noise:
 - Do not lay close or bundle with the main circuit, high-voltage power line, or load line. Otherwise effects of noise or surge induction are likely to take place. Keep a safe distance of more than 100 mm (3.94") from the above when wiring.
 - Ground the shield wire or shield of a shielded cable at one point on the PLC. However, do not ground at the same point as high voltage lines.
- Observe the following items to wire the lines to the European terminal board. Failing to do so may cause electric shock, short circuit, disconnection, or damage of the product.
 - The disposal size of the cable end should follow the dimensions described in this manual.
 - Tighten to a torque should follow the torque described in this manual.
 - Twist the end of strands and make sure there is no loose wires.
 - Do not solder-plate the electric wire ends.
 - Connect only the electric wires of regulation size.
 - Fix the electric wires so that the terminal block and connected parts of electric wires are not directly stressed.
- Properly perform wiring to the terminal block of the FX3U Series PLC following the precautions below in order to prevent electrical shock, short-circuit, breakage of wire, or damage to the product:
 - The disposal size of the cable end should follow the dimensions described in this manual.
 - Tighten to a torque should follow the torque described in this manual.

3.1 Applicable Cable and Terminal Tightening Torque

3.1.1 Terminal block (European type)

- Wire size
Wiring to analog device should use 20-22 AWG wire.
- Applicable cable

Type	Wire size
Single-wire	0.3mm ² to 0.5mm ² (AWG22 to 20)
2-wire	2 pieces of 0.3mm ² (AWG22)

- Termination of cable end
Strip the coating of strand wire and twist the cable core before connecting it, or strip the coating of single wire before connecting it. An alternative connection is to use a ferrule with insulating sleeve.

Manufacturer	Model	Caulking tool
Phoenix Contact Co., Ltd.	AI 0.5-8WH	CRIMPFOX UD6

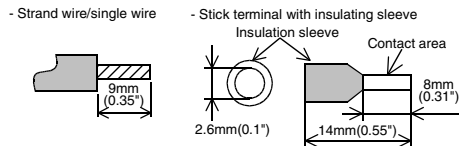

When using a stick terminal with insulating sleeve, choose a wire with proper cable sheath referring to the above outside dimensions, or otherwise, the wire cannot be inserted easily. The tightening torque must be 0.22 to 0.25N-m.

3.2 Power Supply Wiring

→ For the power supply wiring, refer to the FX3U / FX3UC Series User's Manual - Analog Control Edition

3.3 Wiring of Analog Input

→ For the terminal configuration, refer to Section 1.2

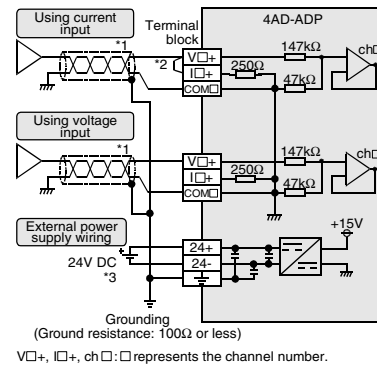

- V□+, I□+, ch□: □ represents the channel number.
- Use 2-core shielded twisted pair cable for the analog input lines, and separate the analog input lines from other power lines or inductive lines.
 - Make sure to short-circuit the 'V□+' and 'I□+' terminals when current is input. (□: input channel number)
 - 24V DC service power supply of the FX3U Series PLC can also be used.

3.4 Grounding

- Grounding should be performed as stated below.
- The grounding resistance should be 100Ω or less.
 - Independent grounding should be performed for best results. When independent grounding is not performed, perform "shared grounding" of the following figure.

→ For details, refer to the FX3U Series User's Manual - Hardware Edition.

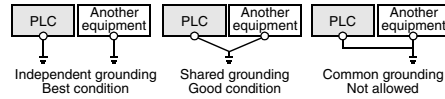

- The grounding wire size should be AWG 22-20 (0.3-0.5 mm²).
- The grounding point should be close to the PLC, and all grounding wire should be as short as possible.

4. Specification

STARTUP AND MAINTENANCE PRECAUTIONS **⚠ CAUTION**

- Do not disassemble or modify the unit. Doing so may cause failure, malfunction or fire. * For repair, contact your local Mitsubishi Electric distributor.
- Do not drop the product or do not exert strong impact, doing so may cause damage.

DISPOSAL PRECAUTIONS **⚠ DANGER**

- Please contact a company certified in the disposal of electronic waste for environmentally safe recycling and disposal of your device.

TRANSPORT AND STORAGE PRECAUTIONS **⚠ CAUTION**

- During transportation avoid any impact as the product is a precision instrument. Check the operation of the product after transportation.

4.1 Applicable PLC

Model name	Applicability
FX3U Series PLC	Ver. 2.00 (from the first product) and later
FX3UC Series PLC	Ver. 1.20 (from the product manufactured in May, 2004 with SER No. 45****) and later

The version number can be checked by monitoring D8001 as the last three digits indicate it.

4.2 General Specification

For the general specification, refer to the manual of the PLC main unit. The items other than the following are equivalent to those of the PLC main unit.

Item	Specification
Dielectric withstand voltage	500V AC for one minute Conforming to JEM-1021 Between all terminals and ground terminal of PLC main unit
Insulation resistance	5MΩ or more by 500V DC megger

4.3 Power Supply Specification

Item	Specification
A/D conversion circuit driving power	24V DC +20%/-15%, 40mA for 24V DC Connect a 24V DC power supply to the terminal block.
Interface driving power	5V DC, 15mA 5V DC power is supplied internally from the main unit.

4.4 Performance Specification

Item	Description	
	Voltage input	Current input
Analog input range	0 to 10V DC (Input resistance: 194 kΩ)	4 to 20mA DC (Input resistance: 250 Ω)
Maximum absolute input	-0.5V, +15V	-2mA, +30mA
Digital output	12 bits, binary	11 bits, binary
Resolution	2.5mV (10V/4000)	10μA (16mA/1600)
Total accuracy	<ul style="list-style-type: none"> ±0.5% (±50mA) for full scale of 10V (when ambient temperature is 25°C±5°C) ±1.0% (±100mA) for full scale of 10V (when ambient temperature is 0°C to 55°C) 	<ul style="list-style-type: none"> ±0.5% (±80μA) for full scale of 16mA (when ambient temperature is 25°C±5°C) ±1.0% (±160μA) for full scale of 16mA (when ambient temperature is 0°C to 55°C)
A/D conversion time	200 μs (The data will be updated at every scan time of the PLC.)	
Input characteristics		
Insulation method	<ul style="list-style-type: none"> The photo-coupler is adopted to insulate the analog input area from the PLC. The DC-DC converter is adopted to insulate the driving power supply line from the analog input area. Channels are not insulated from each other. 	
Occupied points	0 point (This number is not related to the maximum number of input/output points of the PLC.)	

This manual confers no industrial property rights or any rights of any other kind, nor does it confer any patent licenses. Mitsubishi Electric Corporation cannot be held responsible for any problems involving industrial property rights which may occur as a result of using the contents noted in this manual.

Warranty

Mitsubishi will not be held liable for damage caused by factors found not to be the cause of Mitsubishi; machine damage or lost profits caused by faults in the Mitsubishi products; damage, secondary damage, accident compensation caused by special factors unpredictable by Mitsubishi; damages to products other than Mitsubishi products; and to other duties.

⚠ For safe use

- This product has been manufactured as a general-purpose part for general industries, and has not been designed or manufactured to be incorporated in a device or system used in purposes related to human life.
- Before using the product for special purposes such as nuclear power, electric power, aerospace, medicine or passenger movement vehicles, consult with Mitsubishi Electric.
- This product has been manufactured under strict quality control. However when installing the product where major accidents or losses could occur if the product fails, install appropriate backup or failsafe functions in the system.

MITSUBISHI *Changes for the Better*
 PROGRAMMABLE CONTROLLERS
FX3U-4AD-ADP
USER'S MANUAL

Manual Number	JY997D13901
Revision	C
Date	June 2005

This manual describes the part names, dimensions, mounting, and specifications of the product. Before use, read this manual and manuals of relevant products fully to acquire proficiency in handling and operating the product. Make sure to learn all the product information, safety information, and precautions. And, store this manual in a safe place so that you can take it out and read it whenever necessary. Always forward it to the end user.

Registration
 The company name and the product name to be described in this manual are the registered trademarks or trademarks of each company.

Effective June 2005
 Specifications are subject to change without notice.
 © 2005 Mitsubishi Electric Corporation

Safety Precaution (Read these precautions before use.)
 This manual classify the safety precautions into two categories:
 ⚠DANGER and ⚠CAUTION.

DANGER	Indicates that incorrect handling may cause hazardous conditions, resulting in death or severe injury.
CAUTION	Indicates that incorrect handling may cause hazardous conditions, resulting in medium or slight personal injury or physical damage.

Depending on circumstances, procedures indicated by ⚠CAUTION may also be linked to serious results. In any case, it is important to follow the directions for usage.

Associated Manuals

Manual name	Manual No.	Description
FX3U / FX3UC Series User's Manual - Analog Control Edition	JY997D16701 MODEL CODE: 09R619	Describes specifications for analog control and programming method for FX3U / FX3UC Series PLC.
FX3U/FX3UC Series Programming Manual - Basic & Applied Instruction Edition	JY997D16601 MODEL CODE: 09R517	Describes PLC programming for basic/applied instructions and devices.
FX3U Series User's Manual - Hardware Edition	JY997D16501 MODEL CODE: 09R516	Explains FX3U Series PLC specification details for I/O, wiring, installation, and maintenance.

Note: FX3UC Series PLC specification details for I/O, wiring, installation, and maintenance can only be found in the Japanese Manual.

How to obtain manuals
 For the necessary product manuals or documents, consult with the Mitsubishi Electric dealer from where you purchase your product.

Applicable Standard
 FX3U-4AD-ADP made in June, 2005 or later complies with the EC Directive (EMC Directive) and UL standards (UL, cUL). Further information can be found in the following manual. However, FX3UC-32MTLT does not comply with EC Directive (EMC Directive), UL standards (UL, cUL).
 → Refer to FX3U Series Hardware Manual (Manual No. JY997D18801)

Caution for EC Directive
 The analog special adapters have been found to be compliant to the European standards in the aforesaid manual and directive. However, for the very best performance from what are in fact delicate measuring and controlled output device Mitsubishi Electric would like to make the following points:
 As analog devices are sensitive by nature, their use should be considered carefully. For users of proprietary cables (integral with sensors or actuators), these users should follow those manufacturers installation requirements. Mitsubishi Electric recommend that shielded cables should be used. If NO other EMC protection is provided, then users may experience temporary induced errors not exceeding +10%/ -10% in very heavy industrial areas. However, Mitsubishi Electric suggest that if adequate EMC precautions are followed with general good EMC practice for the users complete control system, users should expect normal errors as specified in this manual.

- Sensitive analog cable should not be laid in the same trunking or cable conduit as high voltage cabling. Where possible users should run analog cables separately.
- Good cable shielding should be used. When terminating the shield at Earth - ensure that no earth loops are accidentally created.
- When reading analog values, EMC induced errors can be smoothed out by averaging the readings. This can be achieved either through functions on the analog special adapters or through a users program in the FX3U Series PLC main unit.

1. Outline

The FX3U-4AD-ADP adapter for analog input (hereinafter called 4AD-ADP) is a special adapter to add four analog input points.

1.1 Incorporated Items

Check if the following product and items are included in the package:

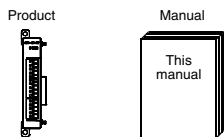

1.2 External Dimensions, Part Names, and Terminal Layout

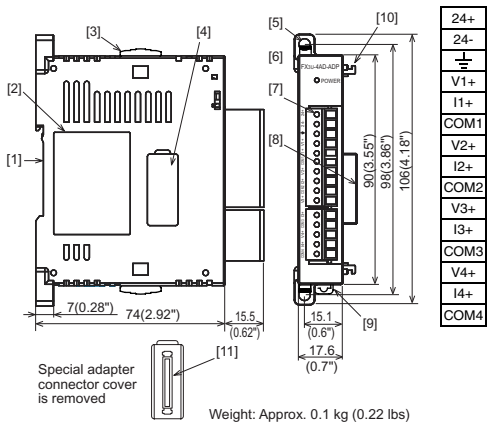

- [1] DIN rail mounting groove (DIN rail: DIN46277)
- [2] Name plate
- [3] Special adapter slide lock: Used to connect special adapter on left side of this special adapter.
- [4] Special adapter connector cover: Remove this cover for connecting special adapter on the left side.
- [5] Direct mounting hole: 2 holes of $\phi 4.5$ (0.18") (mounting screw: M4 screw) Not used when connecting to FX3UC Series PLC.

- [6] POWER LED (green): Lit while 24V DC power is supplied properly to terminals '24+' and '24-'.
- [7] Terminal block (European type): Connect the analog voltage/current signal, and 24V DC power supply.
- [8] Special adapter connector: Used to connect this special adapter to PLC main unit or special adapter.
- [9] DIN rail mounting hook
- [10] Special adapter fixing hook
- [11] Special adapter connector: Used to connect communication special adapter or analog special adapter to this adapter on left side.

2. Installation

The product can be mounted on a DIN rail (DIN46277) or mounted directly using screws.
 For installation/uninstallation and safety precautions, refer to the following manuals:
 → Refer to the FX3U Series User's Manual - Hardware Edition.

INSTALLATION PRECAUTIONS ⚠DANGER

- Cut off all phases of the power source externally before starting the installation or wiring work, thus avoiding electric shock or damages to the product.

INSTALLATION PRECAUTIONS ⚠CAUTION

- Use the product in the environment within the general specifications described in PLC main unit manual (Hardware Edition). Never use the product in areas with dust, oily smoke, conductive dusts, corrosive gas (salt air, Cl₂, H₂S, NH₃, SO₂, or NO₂), flammable gas, vibrations or impacts, or expose it to high temperature, condensation, or wind and rain. If the product is used in such a place described above, electrical shock, fire, malfunction, damage, or deterioration may be caused.
- When drilling screw holes or wiring, cutting chips or wire chips should not enter ventilation slits. Such an accident may cause fire, failure or malfunction.
- Do not touch the conductive parts of the product directly, thus avoiding failure or malfunction.
- Fix the special adapter securely to the specified connector. Incorrect connection may cause malfunction.

2.1 Connection to the FX3U Series PLC

- Refer to the procedure 2) for configuring a new system.
- Refer to the procedure 1) for adding product to an existing system.

Procedure

- 1) Turn off the power. Disconnect all the cables connected to the PLC main unit and special adapter mounted on DIN rail or mounted directly using screws.
- 2) Install an expansion board to the main unit. For installation of expansion board, refer to the following manual:
 → Refer to the FX3U Series User's Manual - Hardware Edition
- 3) Remove the special adapter connector cover on the expansion board (Right fig.A). In case of connecting this product to another special adapter, please replace the 'expansion board' in the above description with a 'special adapter' and perform the procedure as indicated.
- 4) Slide the special adapter slide lock (Right fig.B) of the main unit. In case of connecting this product to another special adapter, please replace the 'main unit' in the above description with a 'special adapter' and perform the procedure as indicated. (Please replace the following procedures similarly.)

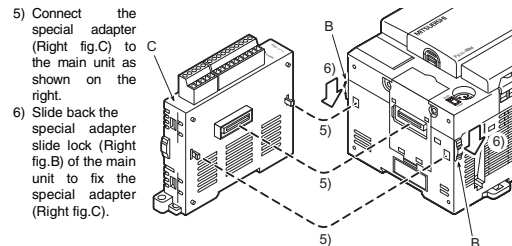
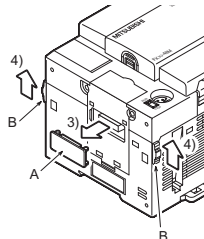

Connection precautions
 Connect all the high-speed I/O special adapters before connecting other special adapters when they are used in combination.
 Do not connect a high-speed I/O special adapter on the left side of a communication or analog special adapter.

2.2 Connection to the FX3UC Series PLC

- Refer to the procedure 2) for configuring a new system.
- Refer to the procedure 1) for adding product to an existing system.

Procedure

- 1) Turn off the power. Disconnect all the cables connected to the PLC. Dismount the PLC from the DIN rail.
- 2) Install an expansion board to the main unit. For installation of expansion board, refer to the following manual:
 → Refer to the manual of the expansion board to be used.

- 3) Remove the special adapter connector cover on the expansion board (Right fig.A). In case of connecting this product to another special adapter, please replace the 'expansion board' in the above description with a 'special adapter' and perform the procedure as indicated.
- 4) Slide the special adapter slide lock (Right fig.B) of the main unit. In case of connecting this product to another special adapter, please replace the 'main unit' in the above description with a 'special adapter' and perform the procedure as indicated. (Please replace the following procedures similarly.)

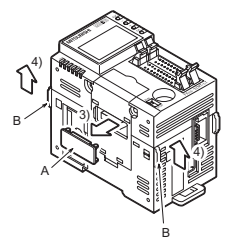

- 5) Connect special adapter (Right fig.C) to the main unit as shown on the right.
- 6) Slide back the special adapter slide lock (Right fig.C) of the main unit to fix the special adapter (Right fig.C).

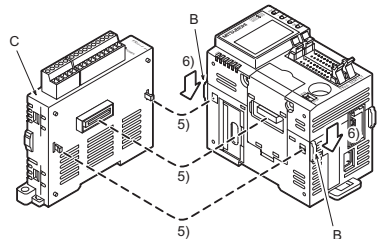

3. Wiring

WIRING PRECAUTIONS ⚠DANGER

- Cut off all phases of power source externally, before installation or wiring work in order to avoid electric shock or damage of product.

WIRING PRECAUTIONS ⚠CAUTION

- Never let cutting chips and wire chips enter the ventilation slits of this product or PLC when performing wiring. Otherwise, fire, failure or malfunction may occur.
- Make sure to observe the precautions below in order to prevent any damage to a machine or any accident which might be caused by abnormal data written in the PLC due to the influence of noise:
 1) Do not lay close or bundle with the main circuit, high-voltage power line, or load line. Otherwise effects of noise or surge induction are likely to take place. Keep a safe distance of more than 100 mm (3.94") from the above when wiring.
 2) Ground the shield wire or shield of a shielded cable at one point on the PLC. However, do not ground at the same point as high voltage lines.
- Observe the following items to wire the lines to the European terminal board. Failing to do so may cause electric shock, short circuit, disconnection, or damage of the product.
 - The disposal size of the cable end should follow the dimensions described in this manual.
 - Tighten to a torque should follow the torque described in this manual.
 - Twist the end of strands and make sure there is no loose wires.
 - Do not solder-plate the electric wire ends.
 - Connect only the electric wires of regulation size.
 - Fix the electric wires so that the terminal block and connected parts of electric wires are not directly stressed.
- Properly perform wiring to the terminal block of the FX3U Series PLC following the precautions below in order to prevent electrical shock, short-circuit, breakage of wire, or damage to the product:
 - The disposal size of the cable end should follow the dimensions described in this manual.
 - Tighten to a torque should follow the torque described in this manual.

3.1 Applicable Cable and Terminal Tightening Torque

3.1.1 Terminal block (European type)

- 1) Wire size
 Wiring to analog device should use 20-22 AWG wire.
- 2) Applicable cable

Type	Wire size
Single-wire	0.3mm ² to 0.5mm ² (AWG22 to 20)
2-wire	2 pieces of 0.3mm ² (AWG22)

- 3) Termination of cable end
 Strip the coating of strand wire and twist the cable core before connecting it, or strip the coating of single wire before connecting it. An alternative connection is to use a ferrule with insulating sleeve.

Manufacturer	Model	Caulking tool
Phoenix Contact Co., Ltd.	AI 0.5-8WH	CRIMPOFOX UD6

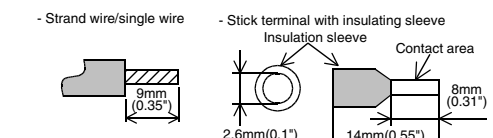

When using a stick terminal with insulating sleeve, choose a wire with proper cable sheath referring to the above outside dimensions, or otherwise, the wire cannot be inserted easily. The tightening torque must be 0.22 to 0.25N·m.

3.2 Power Supply Wiring

→ For the power supply wiring, refer to the FX3U / FX3UC Series User's Manual - Analog Control Edition

3.3 Wiring of Analog Input

→ For the terminal configuration, refer to Section 1.2

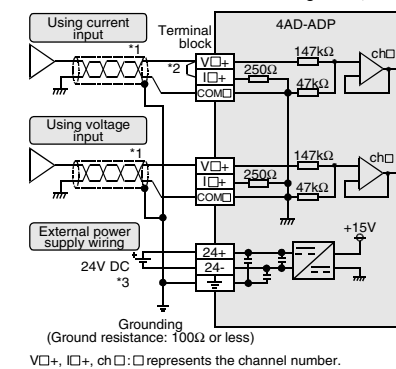

- *1 Use 2-core shielded twisted pair cable for the analog input lines, and separate the analog input lines from other power lines or inductive lines.
- *2 Make sure to short-circuit the 'V□+' and 'I□+' terminals when current is input. (□: input channel number)
- *3 24V DC service power supply of the FX3U Series PLC can also be used.

3.4 Grounding

Grounding should be performed as stated below.
 • The grounding resistance should be 100Ω or less.
 • Independent grounding should be performed for best results. When independent grounding is not performed, perform 'shared grounding' of the following figure.

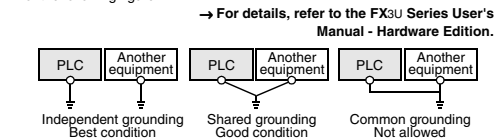

- The grounding wire size should be AWG 22-20 (0.3-0.5 mm²).
- The grounding point should be close to the PLC, and all grounding wire should be as short as possible.

4. Specification

STARTUP AND MAINTENANCE PRECAUTIONS ⚠CAUTION

- Do not disassemble or modify the unit. Doing so may cause failure, malfunction or fire.
 * For repair, contact your local Mitsubishi Electric distributor.
- Do not drop the product or do not exert strong impact, doing so may cause damage.

DISPOSAL PRECAUTIONS ⚠DANGER

- Please contact a company certified in the disposal of electronic waste for environmentally safe recycling and disposal of your device.

TRANSPORT AND STORAGE PRECAUTIONS ⚠CAUTION

- During transportation avoid any impact as the product is a precision instrument. Check the operation of the product after transportation.

4.1 Applicable PLC

Model name	Applicability
FX3U Series PLC	Ver. 2.00 (from the first product) and later
FX3UC Series PLC	Ver. 1.20 (from the product manufactured in May, 2004 with SER No. 45****) and later

The version number can be checked by monitoring D8001 as the last three digits indicate it.

4.2 General Specification

For the general specification, refer to the manual of the PLC main unit. The items other than the following are equivalent to those of the PLC main unit.

Item	Specification
Dielectric withstand voltage	500V AC for one minute Conforming to JEM-1021 Between all terminals and ground terminal of PLC main unit
Insulation resistance	5MΩ or more by 500V DC megger

4.3 Power Supply Specification

Item	Specification
A/D conversion circuit driving power	24V DC +20%/-15%, 40mA for 24V DC Connect a 24V DC power supply to the terminal block.
Interface driving power	5V DC, 15mA 5V DC power is supplied internally from the main unit.

4.4 Performance Specification

Item	Description	
	Voltage input	Current input
Analog input range	0 to 10V DC (Input resistance: 194 kΩ)	4 to 20mA DC (Input resistance: 250 Ω)
Maximum absolute input	-0.5V, +15V	-2mA, +30mA
Digital output	12 bits, binary	11 bits, binary
Resolution	2.5mV (10V/4000)	10μA (16mA/1600)
Total accuracy	<ul style="list-style-type: none"> • ±0.5% (±50mA) for full scale of 10V (when ambient temperature is 25°C±5°C) • ±1.0% (±100mA) for full scale of 10V (when ambient temperature is 0°C to 55°C) 	<ul style="list-style-type: none"> • ±0.5% (±80μA) for full scale of 16mA (when ambient temperature is 25°C±5°C) • ±1.0% (±160μA) for full scale of 16mA (when ambient temperature is 0°C to 55°C)
A/D conversion time	200 μs (The data will be updated at every scan time of the PLC.)	
Input characteristics		
Insulation method	<ul style="list-style-type: none"> • The photo-coupler is adopted to insulate the analog input area from the PLC. • The DC-DC converter is adopted to insulate the driving power supply line from the analog input area. • Channels are not insulated from each other. 	
Occupied points	0 point (This number is not related to the maximum number of input/output points of the PLC.)	

This manual confers no industrial property rights or any rights of any other kind, nor does it confer any patent licenses. Mitsubishi Electric Corporation cannot be held responsible for any problems involving industrial property rights which may occur as a result of using the contents noted in this manual.

Warranty
 Mitsubishi will not be held liable for damage caused by factors found not to be the cause of Mitsubishi; machine damage or lost profits caused by faults in the Mitsubishi products; damage, secondary damage, accident compensation caused by special factors unpredictable by Mitsubishi; damages to products other than Mitsubishi products; and to other duties.

For safe use

- This product has been manufactured as a general-purpose part for general industries, and has not been designed or manufactured to be incorporated in a device or system used in purposes related to human life.
- Before using the product for special purposes such as nuclear power, electric power, aerospace, medicine or passenger movement vehicles, consult with Mitsubishi Electric.
- This product has been manufactured under strict quality control. However when installing the product where major accidents or losses could occur if the product fails, install appropriate backup or failsafe functions in the system.