

MITSUBISHI

Analog-Digital Converter Module Type A1S68AD

User's Manual

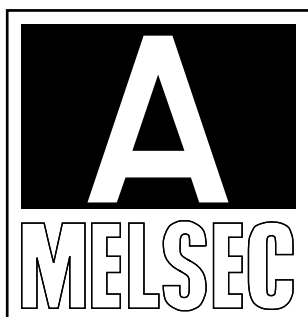
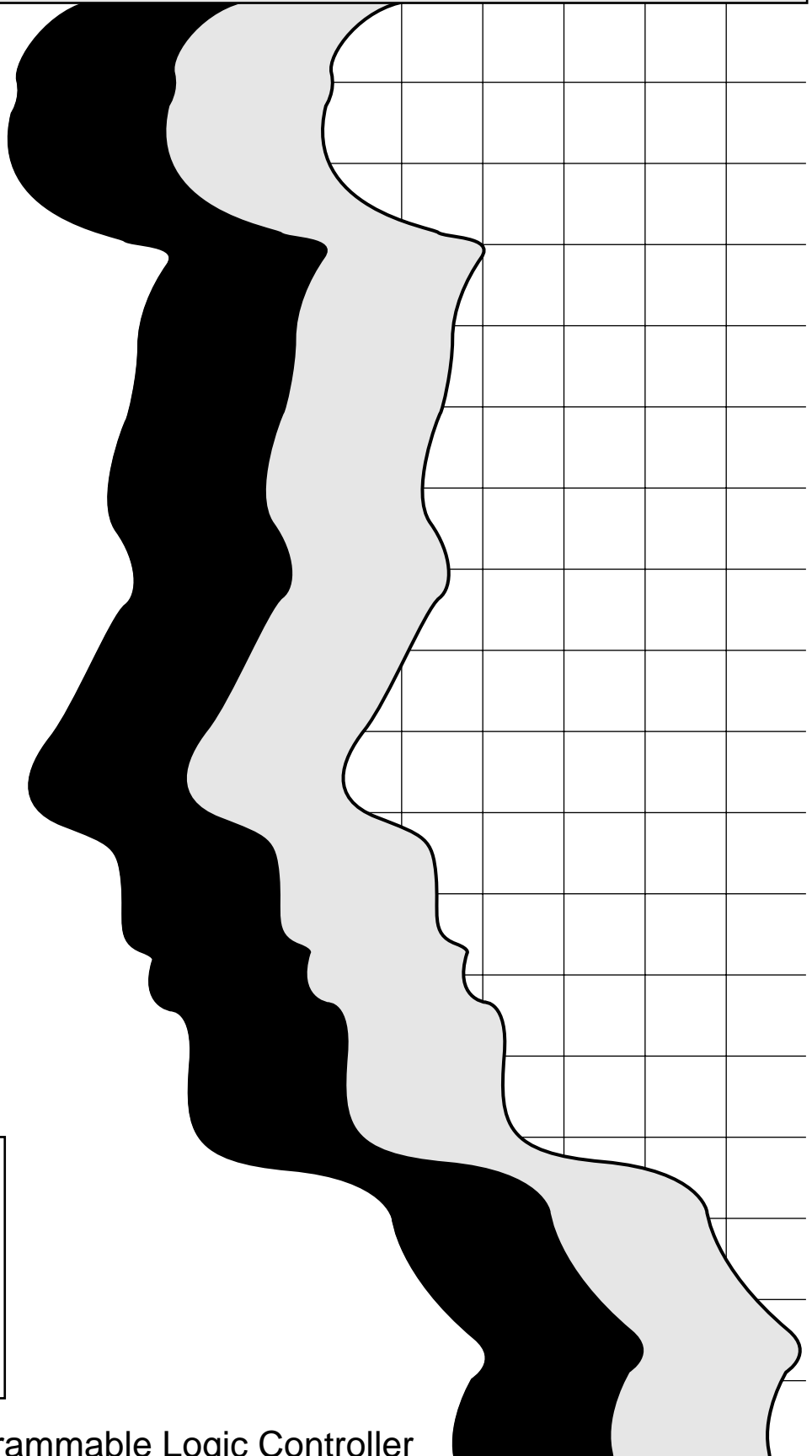

Mitsubishi Programmable Logic Controller

● SAFETY PRECAUTIONS ●

(You must read these cautions before using the product)

In connection with the use of this product, in addition to carefully reading both this manual and the related manuals indicated in this manual, it is also essential to pay due attention to safety and handle the product correctly.

The instructions given in this manual are concerned with this product.

Refer to User's Manual of the CPU module in Use for details on the safety instructions for the programmable logic controller system.

These SAFETY CAUTIONS are classified into two grades: "DANGER" and "CAUTION"



DANGER

Safety caution given when incorrect handling could result in hazardous situations involving the possibility of death or serious injury.



CAUTION

Safety caution given when incorrect handling could result in hazardous situations involving the possibility of moderate or light injury or damage to property.

Note that, depending on the circumstances, failing to follow a  **CAUTION** may also have very serious consequences.

Both of these classes of safety caution are very important and must be observed.

Store this manual carefully in a place where it is accessible for reference whenever necessary, and forward a copy of the manual to the end user.

[Cautions on Design]

 **CAUTION**

- Do not bundle control lines or communication wires together with main circuit or power lines, or lay them close to these lines.
As a guide, separate the lines by a distance of at least 100 mm, otherwise malfunctions may occur due to noise.

[Cautions on Mounting]

 **CAUTION**

- Use the PLC in an environment that conforms to the general specifications in this manual.
Using the PLC in environments outside the ranges states in the general specifications will cause electric shock, fire, malfunction, or damage to/deterioration of the product.
- Insert the tabs at the bottom of the module into the holes in the base module before installing module. Be sure to install the module in the base module with screws tightened to the specified torque.
Improper installation may cause erroneous operation, accident, or the module to fall out.

[Cautions on Wiring]

 **CAUTION**

- Carry out wiring to the PLC correctly, checking the rated voltage and terminal arrangement of the product.
Using a power supply that does not conform to the rated voltage, or carrying out wiring incorrectly, will cause fire or failure.
- Tighten the terminal screws within the specified torque range.
Undertightening can cause a short circuit or malfunction.
Overtightening can cause a short circuit or malfunction due to damage of the screws or module.
- Make sure that no foreign matter such as chips or wiring offcuts gets inside the module. It will cause fire, failure or malfunction.

[Cautions on Startup and Maintenance]

 **DANGER**

- Do not touch terminals while the power is ON.
This will cause malfunctions.
- Start cleaning or terminal screw retightening after switching power off externally in all phases.
Not doing so can cause failure or malfunction of the module.

 **CAUTION**

- Do not disassemble or modify any module.
This will cause failure, malfunction, injuries, or fire.
- Mount or dismount the module after switching power off externally in all phases.
Not doing so can cause failure or malfunction of the module.
- Inputting a voltage input in a current input range may cause failure.
- Always make sure to touch the grounded metal to discharge the electricity charged in the body, etc., before touching the module.
Failure to do so may cause a failure or malfunction of the module.

[Cautions on Disposal]

 **CAUTION**

- Dispose of this product as industrial waste.

REVISIONS

*The manual number is given on the bottom left of the back cover.

Print Date	*Manual Number	Revision
Sep., 1995	IB (NA)-66576-A	First edition
Apr., 2001	IB (NA)-66576-B	<p>Addition WARRANTY</p> <p>Correction SAFETY PRECAUTIONS, Chapter 2, Section 3.1, 3.2, 3.3, 3.3.1, 3.3.2, 3.3.3, 3.4, 3.7, 3.7.4, 4.1, 4.2, 4.3.2, 5.1, 5.2, 5.3</p>
Jun, 2003	IB (NA)-66576-C	<p>Correction SAFETY PRECAUTIONS, Section 3.1, 4.2, 4.3.2</p>
Jun, 2004	IB (NA)-66576-D	<p>Reflection of Technical News No. T12-0017 contents</p> <p>Addition Section 2.2, APPENDIX 2</p> <p>Correction Section 3.3.1, Chapter 5</p>

INTRODUCTION

Thank you for choosing the Mitsubishi MELSEC-A Series of General Purpose Programmable Controllers. Please read this manual carefully so that the equipment is used to its optimum. A copy of this manual should be forwarded to the end User.

CONTENTS

1. INTRODUCTION	1-1
1.1 Features	1-1
2. SYSTEM CONFIGURATIONS	2-1-2-2
2.1 Applicable Systems	2-1
2.2 How to Check the Hardware Version	2-2
3. SPECIFICATIONS	3-1-3-16
3.1 General Specifications	3-1
3.2 Performance Specifications	3-2
3.3 I/O Conversion Characteristics	3-3
3.3.1 Voltage input characteristics	3-4
3.3.2 Current input characteristics	3-5
3.3.3 Overall accuracy	3-6
3.4 Functions List	3-7
3.5 Maximum Conversion Speed	3-8
3.5.1 Conversion speed for one channel	3-8
3.5.2 Influence on the maximum conversion speed by executing the FROM/TO instruction	3-8
3.6 CPU I/O Signals	3-9
3.6.1 Overview of I/O signals	3-9
3.6.2 I/O signal functions	3-10
3.7 Buffer Memory	3-11
3.7.1 Buffer memory assignment	3-11
3.7.2 Setting of A-D conversion-enable/disable	3-12
3.7.3 Setting of the sampling process/averaging process	3-13
3.7.4 Digital output value	3-15
3.7.5 Writing data error code	3-15
3.7.6 A-D conversion completed flag	3-16
4. PRE-OPERATION SETTINGS AND PROCEDURES	4-1-4-5
4.1 Handling Instructions	4-1
4.2 Names and settings of each section	4-2
4.3 Wiring	4-3
4.3.1 Wiring instructions	4-3
4.3.2 Connection example of module	4-4
4.4 Check and Maintenance	4-5
5. PROGRAMMING	5-1-5-4
5.1 Programming Procedure	5-1
5.2 Basic Program for Read/Write	5-2
5.3 Initial Setting Program and Example of Digital Output Value Read Program	5-3

6. TROUBLESHOOTING	6-1-6-2
6.1 Error Code List	6-1
6.2 Troubleshooting	6-2
6.2.1 When the RUN LED of A1S68AD Flashes	6-2
6.2.2 When the RUN LED of A1S68AD goes OFF	6-2
6.2.3 When the digital output value cannot be read	6-2
 APPENDICES	 APP-1 ~ APP-5
APPENDIX 1 COMPARISON OF PERFORMANCE BETWEEN A1S68AD AND A1S64AD	APP-1
APPENDIX 2 VOLTAGE INPUT CHARACTERISTIC OF HARDWARE VERSION N OR EARLIER	APP-2
APPENDIX 3 OUTSIDE DIMENSIONS	APP-3

Conformation to the EMC Directive and Low Voltage Instruction

For details on making Mitsubishi PLC conform to the EMC directive and low voltage instruction when installing it in your product, please see Chapter 3, "EMC Directive and Low Voltage Instruction" of the User's Manual (Hardware) of the CPU module to use.

The CE logo is printed on the rating plate on the main body of the PLC that conforms to the EMC directive and low voltage instruction.

By making this product conform to the EMC directive and low voltage instruction, it is not necessary to make those steps individually.

1. INTRODUCTION

This manual describes specifications, handling, programming and other information on the A1S68AD analog to digital converter module (referred to as "A1S68AD") for use with a MELSEC-A series A1SCPU module (hereafter called the PLC CPU).

A1S68AD is used to convert an analog signal (voltage or current input) from an external device of a PLC into a digital value signed 16 bit BIN data.

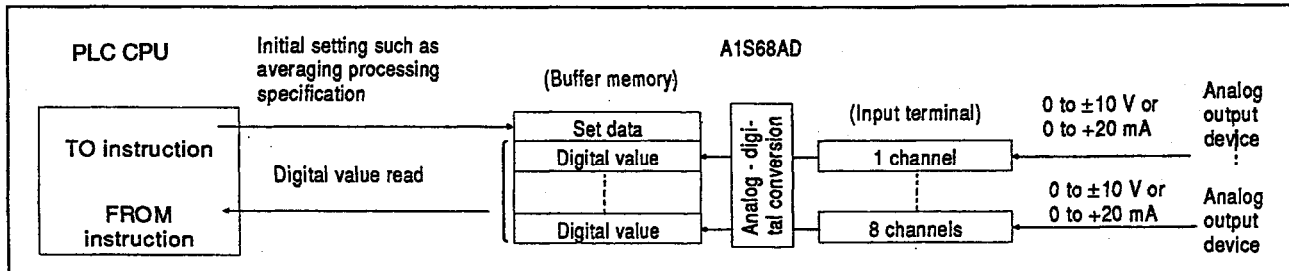

1.1 Features

A1S68AD has the following features.

- (1) Allows analog to digital conversion for 8 channels. A-D conversion of 8 channels is enabled with an A1S68AD.

Voltage input and current input can be selected for each channel by using DIP switches.

- (2) Allows selection of the processing method (for each channel).

One of the following processing methods can be selected for each channel:

- (a) Sampling processing method whereby digital values are stored one by one in the buffer memory after each A-D conversion.
 - (b) Averaging processing method whereby A-D conversion is performed the preset number of times or for the preset duration and the mean value of the converted values is stored in the buffer memory as a digital value.
- (3) Allows conversion of the enable/disable setting. (Every channel)

The A-D conversion of the enable/disable setting can be set for every channel. The conversion speed can then be shortened by setting an unused channel to conversion disable.

- (4) Allows selection of the input range by using DIP switches (for each channel).

The input range can be selected for each channel by using DIP switches. The module has an automatic offset compensation function, making offset/gain adjustment unnecessary.

- (5) Allows high-speed A-D conversion.

A-D conversion can be performed at a speed of 0.5 ms per channel.

2. SYSTEM CONFIGURATIONS

2.1 Applicable Systems

(1) Applicable CPU

- A1SCPU(S1)
- A1SJCPU(S3)
- A1SCPUC24-R2
- A2SCPU(S1)
- A2ASCPU(S1/S30)
- A1SHCPU
- A1SJHCPU(S8)
- A2SHCPU(S1)
- A2USHCPU-S1
- A52GCPU
- Q2ASCPU(S1)
- Q2ASHCPU(S1)

(2) Loadable number of A1S68ADs

Any number of A1S68ADs can be loaded provided the number of I/O points of the applicable PLC CPU is not exceeded.

(3) Loading slot

Except in the following cases, an A1S68AD can be loaded in any slot of a base unit.

If an A1S68AD is installed on an extension base unit without a power supply unit (A1S52B(S1), A1S55B(S1) or A1S58B(S1)), the power capacity may be insufficient.

If such installation is unavoidable, select a proper power supply unit, main and extension base units and extension cable, taking the following factors into consideration:

- (a) the capacity of the power supply unit on the main base unit,
- (b) voltage drop in the main base unit,
- (c) voltage drop in the extension base unit, and
- (d) voltage drop in the extension cable.

(4) Data link system

The A1S68AD can be loaded at any of the master, local and remote I/O stations of a data link system. For examples of remote I/O station programs, refer to the MELSECNET and MELSECNET/B Data Link System Reference Manuals.

REMARK

For I/O point ranges and calculation of voltage drop, refer to the following manuals:

- A1SJCPU(S3) User's Manual IB (NA) 66446
- A1S/A1SC24-R2/A2SCPU(S1) User's Manual IB (NA) 66320
- A2ASCPU(S1/S30) User's Manual IB (NA) 66455
- A2USHCPU-S1 User's Manual IB (NA) 66789
- A1SJH(S8)/A1SH/A2SHCPU(S1) User's Manual IB (NA) 66779
- Q2AS(H)CPU(S1) User's Manual SH (NA) 3599

2.2 How to Check the Hardware Version

The hardware version for the A1S68AD can be checked on the label on the front of the module.

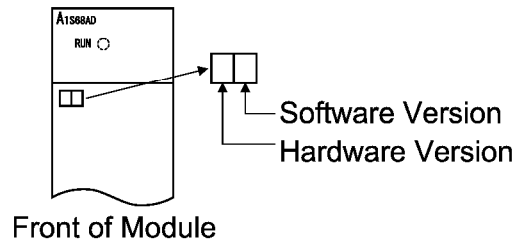

3. SPECIFICATIONS

MELSEC-A

3. SPECIFICATIONS

This chapter describes the general specifications, performance specifications, I/O conversion characteristics, and buffer memory specifications of the A1S68AD.

3.1 General Specifications

Table 3.1 shows the general specifications of the A1S68AD.

Table 3.1 General Specifications

Item	Specifications					
Operating ambient temperature	0 to 55°C					
Storage ambient temperature	-20 to 75°C					
Operating ambient humidity	10 to 90%RH, non-condensing					
Storage ambient humidity	10 to 90%RH, non-condensing					
Vibration resistance	Conforming to JIS B 3502, IEC 61132-2	When there is Intermittent vibration	Frequency	Acceleration	Amplitude	Sweep Count 10 times each in X, Y and Z axis (80 minutes)
			10 to 57 Hz	—	0.075 mm (0.0030inch)	
		When there is continuous vibration	57 to 150 Hz	9.8m/s ²	—	
			10 to 57 Hz	—	0.035 mm (0.0013inch)	
			57 to 150 Hz	4.9m/s ²	—	
Shock resistance	Conforming to JIS B 3502, IEC 61132-2 (147m/s ² , 3 times each in 3 directions)					
Operating environment	No corrosive gas present					
Operating height	2000 m (6562 ft) or less					
Installation area	On the control board					
Over-voltage category *1	II or less					
Pollution rate *2	2 or less					

*1: Indicates the distribution area where the device is assumed to be connected, from the public power distribution network to the local machine device.

Category II is applied to the devices to which the power is supplied from a fixed equipment.

The surge resistance voltage of a rated 300 V device is 2500 V.

*2: This is an index which indicates the occurrence rate of the conductive object in the environment where the device is used.

Pollution rate II indicates that only non-conductive pollution may occur with a possibility of generating temporary conductivity due to accidental condensation.

*3: Do not operate or store the PLC in the environment where the pressure applied is equal to greater than the atmospheric pressure at the altitude of 0m.

Doing so may cause a malfunction. Please consult our branch office when the PLC is to be operated under pressure.

3. SPECIFICATIONS

MELSEC-A

3.2 Performance Specifications

Table 3.2 shows the performance specifications of the A1S68AD.

Table 3.2 Performance Specifications

Item	Specifications	
Analog input	Voltage: DC -10 to 0 to +10 V (Input resistance: 1 M Ω) Current: 0 to +20 mA (Input resistance: 250 Ω)] Can be selected by setting DIP switches.
Digital output	Signd 16 binary	
I/O characteristics (*1)	Analog input	Digital output
	0 to +10 V -10 to 10 V 0 to 5V or 0 to 20 mA 1 to 5V or 4 to 20 mA	0 to +4000 -2000 to +2000 0 to +4000 0 to +4000
Maximum resolution	Analog input	Digital output
	0 to +10 V -10 to 10V 0 to 5 V 1 to 5 V 0 to 20 mA 4 to 20 mA	2.5 mV 5 mV 1.25 mV 1 mV 5 μ A 4 μ A
Overall accuracy (accuracy to full scale)	$\pm 1.0\%$ (Digital output value ± 40)	
Maximum conversion speed	0.5 ms/channel (*2)	
Absolute maximum Input	Voltage: ± 35 V Current: ± 30 mA	
Analog input points	8 channels/module	
Insulation method	Photocoupler insulation between input terminals and PC power (No insulation between channels)	
Number of I/O points	Special 32 points	
Connection terminal	20 point terminal block	
External power supply	Not required	
Applicable wire size	0.75 to 1.5 mm ²	
Applicable solderless terminal	R1.25-3, 1.25-YS3, RAV1.25-3, V1.25-YS3A	
Internal current consumption (5 V DC)	0.4 A	
Weight	0.27 kg	

*1 The switch is set to the analog input value 0 to +10 V on delivery.

*2 The maximum conversion speed is 1 ms/channel on all channels if averaging processing is set even for only one channel.

POINT

The available analog input range for the overall accuracy is as follows:

Voltage : -10 to 0 to +10 V
Current : 0 to +20 mA

3.3 I/O Conversion Characteristics

The I/O conversion characteristic is the gradient observed when analog signals (voltage or current input) sent from a source external to the PLC are converted into digital values.

3.3.1 Voltage input characteristics

In the case of a voltage input that exceeds the practical analog input range (-10V to +10V) indicated in the performance specifications, a digital output value changes depending on the hardware version. Fig. 3.1 shows a voltage input characteristic graph example for the hardware version P or later. Refer to Appendix 2 for a voltage input characteristic graph example for the hardware version N or earlier.

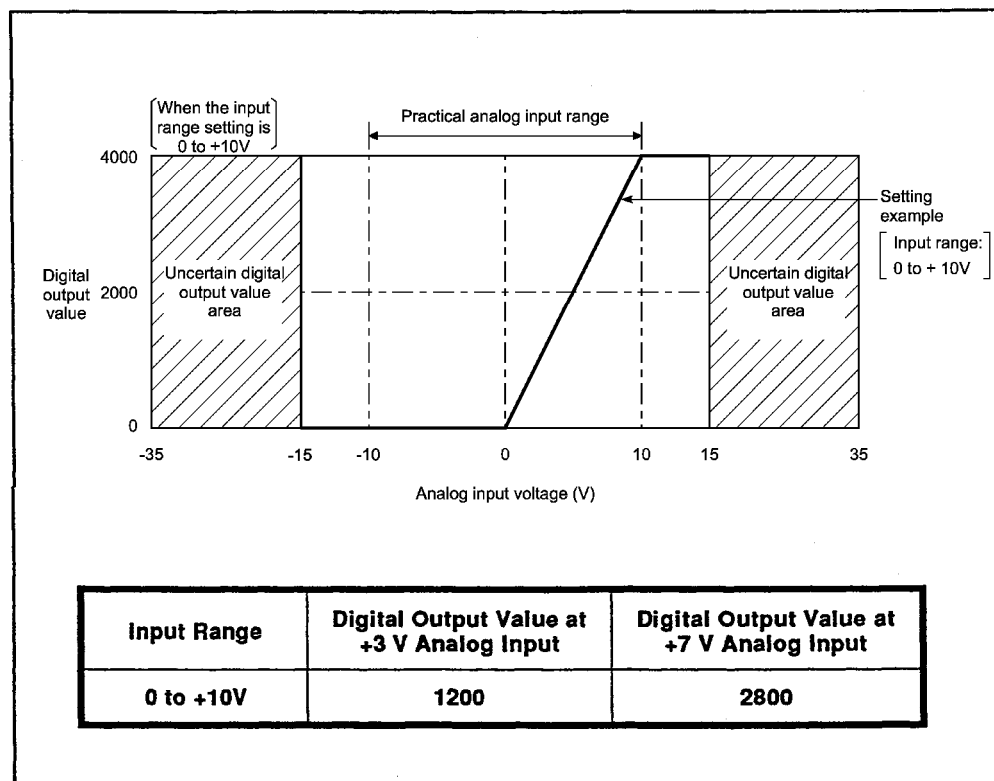

Fig 3.1 Voltage Input Characteristic of Hardware Version P or Later

POINTS

- (1) Do not input voltage ± 35 V or more. Otherwise, elements may be broken.
- (2) If an analog input value which, on conversion, will generate a digital output value exceeding the maximum (2000/4000) or minimum (-2000/0) digital output value set for the input range is input at the digital input voltage of within the range -15 to +15V, the digital output value is fixed at the maximum (2000/4000) or minimum (-2000/0) digital value set for the input range.
- (3) When the analog input voltage is outside a range of -15V to +15V, the digital output value cannot be assured.

3.3.2 Current input characteristics

Figure 3.2 is a graph showing an example of the voltage input characteristic after the input range setting has been changed.

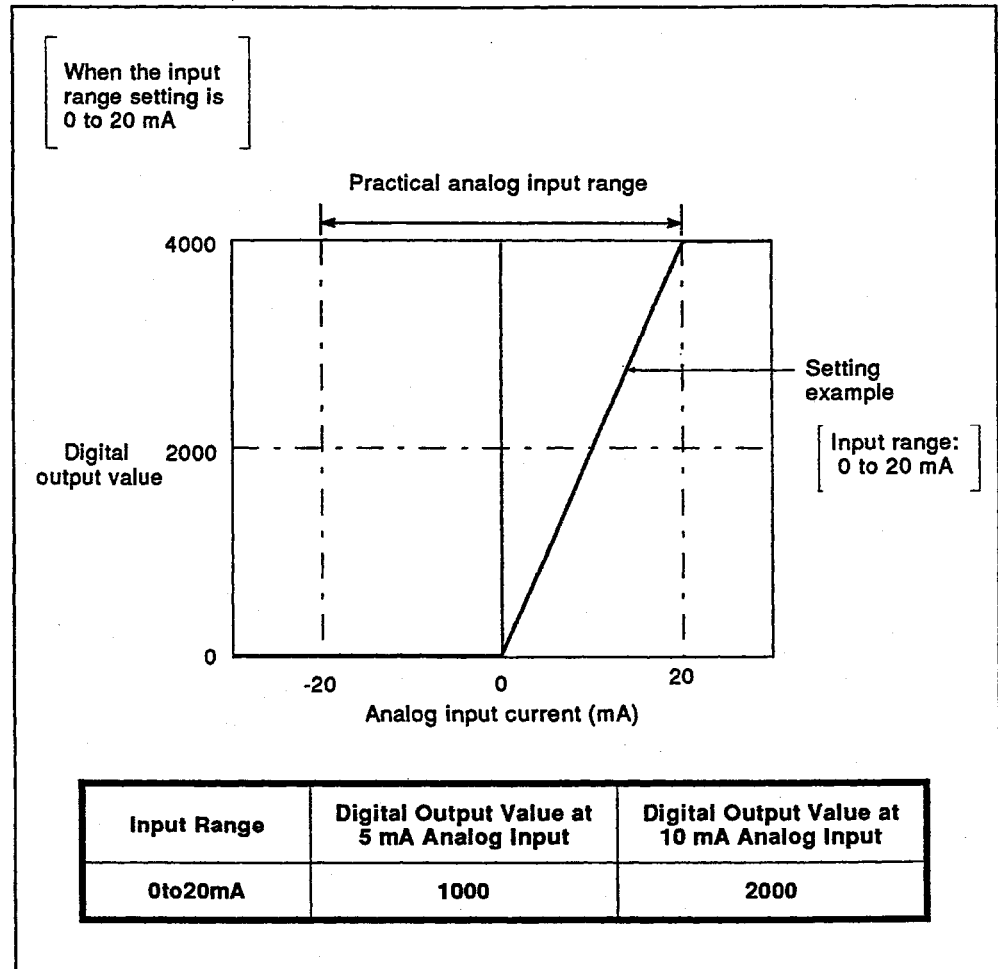

Fig 3.2 Voltage Input Characteristics

POINTS

- (1) Do not input a voltage ± 30 mA or more. Otherwise, a high temperature will occur and cause a problem.
- (2) In the case of an analog input value which, on conversion, will generate a digital output value exceeding the maximum (4000) or minimum (0) digital output value set for the input range, the digital output value is fixed at the maximum (4000) or minimum (0) digital value set for the input range.

3.3.3 Overall accuracy

The overall accuracy is the accuracy with respect to the full-scale digital output value.

Even if the input range setting is changed and the I/O characteristic varies accordingly, the overall accuracy does not change, and remains within the range specified in the Performance Specifications table.

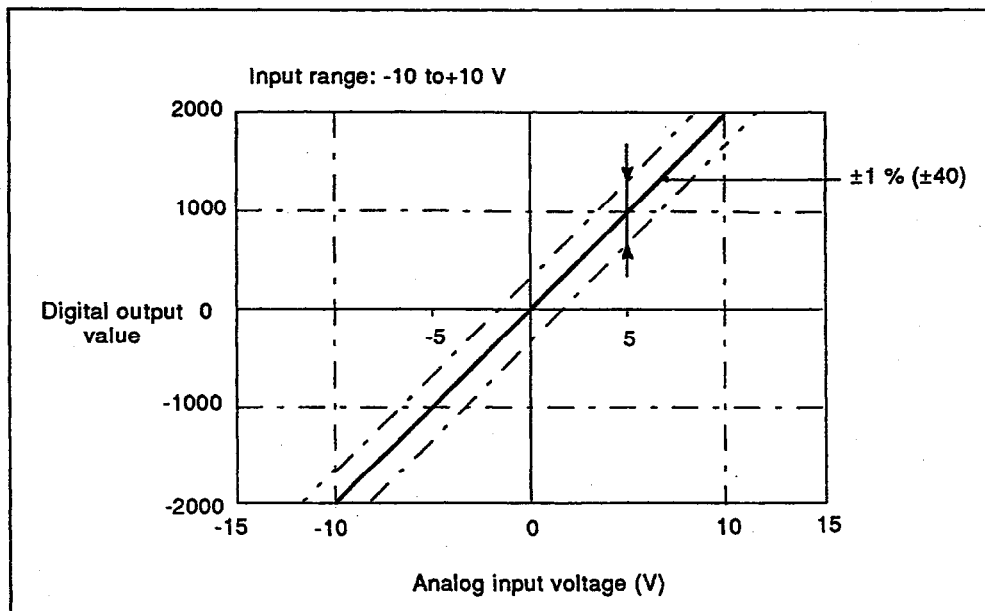

Fig 3.3 Overall Accuracy of the Voltage Input Characteristics

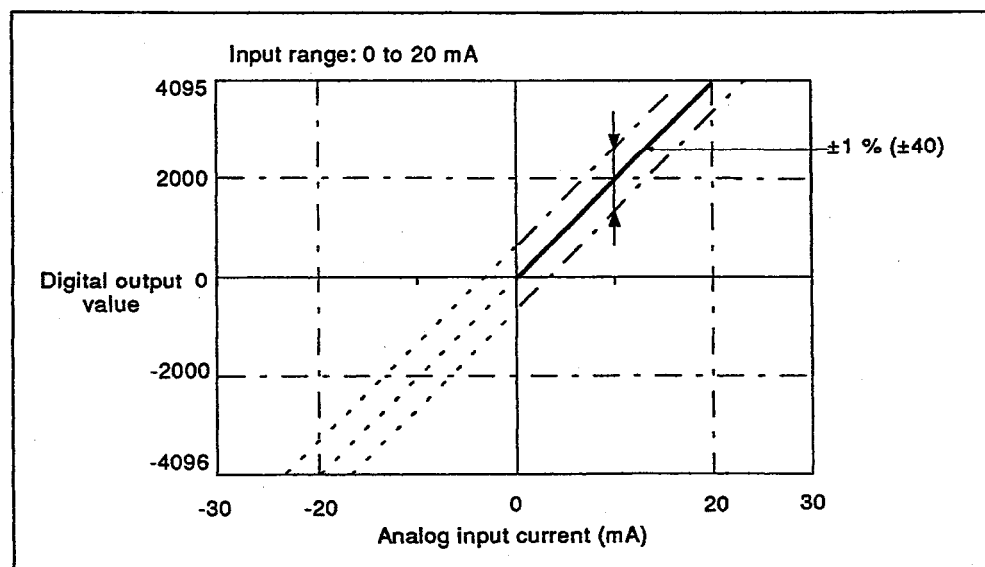

Fig 3.4 Overall Accuracy of the Current Input Characteristics

3.4 Functions List

Table 3.3 shows the functions of A1S68AD.

Table 3.3 A1S68AD Functions List

Item	Description	Reference
A-D conversion-enable/disable setting	<ul style="list-style-type: none"> • A-D conversion enable/disable is specified for each channel. (Default: All channels are set to "enable".) • Sampling time can be shortened by switching the unused channel to "disable". 	Section 3.7.2
Input range setting	<ul style="list-style-type: none"> • The input range can be set for each channel, and the I/O conversion characteristic can be changed. 	Section 3.3 Section 4.2
Averaging process specification	<ul style="list-style-type: none"> • A-D conversion is done for the each channel with a setting count or setting time. The averaging process is done for the A-D conversion data, and the average is set to the buffer memory as the digital output value. 	Section 3.7.3
Sampling process specification	<ul style="list-style-type: none"> • Analog input value is converted to the digital value for each channel, and is stored in the buffer memory as the digital output value. 	Section 3.7.3

3.5 Maximum Conversion Speed

Conversion speed is the time it takes when a digital value is written to the buffer memory after the A-D conversion by switching channel.

The following explains the maximum conversion speed.

3.5.1 Conversion speed for one channel

Conversion speed for one channel of A1S68AD is 0.5 ms.

When several channels are used, "0.5 ms x the number of conversion-enabled channels" equals the sampling time.

The conversion speed is 1 ms/channel on all channels if averaging processing is selected even for only one channel.

3.5.2 Influence on the maximum conversion speed by executing the FROM/TO instruction

When the FROM/TO instruction is not executed, the maximum conversion speed is as mentioned above. Executing the FROM/TO instruction influences the maximum conversion speed as follows.

- (1) If the time it takes to write a digital value converted from an analog value overlaps with the execution of FROM/TO processing, writing to the buffer memory is delayed until the FROM/TO processing is completed.
- (2) If the time it takes for the switching channel overlaps with the execution of FROM/TO processing, the switching channel is delayed until the FROM/TO processing is completed.
- (3) When a digital value that has been converted from an analog value is being written to the buffer memory with the switching channel, the FROM/TO processing is delayed until the writing or switching channel is completed.
- (4) Designate the FROM/TO instruction to read and write a lot of data at one time. The smaller the number of FROM/TO instructions, the less the maximum conversion speed is influenced.

3. SPECIFICATIONS

3.6 CPU I/O Signals

This section explains the allocation of the I/O signals and the function of each signal.

3.6.1 Overview of I/O signals

The A1S68AD uses 32 signal points for input and output.

Table 3.4 gives the allocation and description of the I/O signals.

X devices refer to the input signals from the A1S68AD to the PLC CPU.

Y devices refer to output signals from the PLC CPU to the A1S68AD.

The device numbers (input signals) shown in the table are used when the A1S68AD is loaded into slot 0 of the main base unit.

Table 3.4 I/O Signals

Signal Direction: A1S68AD → PC CPU		Signal Direction: PC CPU → A1S68AD	
Device No.	Signal Description	Device No.	Signal Description
X0	WDT error flag	Y0 to Y11	Unusable
X1	A-D conversion READY		
X2	Error flag	Y12	Error reset
X3 to X1F	Unusable	Y13 to Y1F	Unusable

POINT

If any of the devices (Y0 to Y11, and Y13 to Y1F) are used (turned ON/OFF) in the sequence program, the functions of the A1S68AD cannot be guaranteed.

If any of the devices Y0 to Y1F has the same number as any of the devices X0 to X1F, then the device cannot be used as an internal relay.

3. SPECIFICATIONS

3.6.2 I/O signal functions

The following table explains the function of each I/O signal of A1S68AD.

Table 3.5 I/O Signal Functions

Device No.	Signal	Description	Remark
X0	WDT (watch-dog timer) error flag	This flag is set when the self-diagnosis function of the A1S68AD detects a WDT error.	<ul style="list-style-type: none"> While the error flag is set, the A-D conversion of the A1S68AD will not RUN. If the error flag (X0) is set, hardware malfunction may occur.
X1	A-D conversion READY	<ul style="list-style-type: none"> This signal is turned ON when the A/D conversion is ready after turning on or resetting the CPU. The A/D conversion READY signal (X1) can also be used as the buffer memory read/write interlock. 	<ul style="list-style-type: none"> A-D conversion READY indicates the point in time when A-D conversion has been completed once on all channels for which A-D conversion is enabled and the digital output values have been stored in the buffer memory.
X2	Error flag	<ul style="list-style-type: none"> This flag is set when an error other than the watch dog timer error occurs in the A1S68AD. If the error reset signal is set, the error code is stored in the error code storage area. If the error reset signal is turned ON, this error flag is reset. 	
Y12	Error reset	<ul style="list-style-type: none"> Turning ON the error reset signal resets the error flag, and clears the check code of the buffer memory. It is replaced by "0". The RUN LED on the front of the module is switched to ON (normal operation) from flashing (error). 	<p>The diagram illustrates the relationship between the Error flag (X2), Error reset signal (Y12), and Buffer memory addresses 1. The Error code is shown as a pulse between addresses 1. The Error flag (X2) is set when the Error code is present. The Error reset signal (Y12) is set by the sequence program, which resets the Error flag (X2) and clears the Error code. The Error code is also cleared by the system's Set/Reset signal.</p>

3. SPECIFICATIONS

3.7 Buffer Memory

The A1S68AD has a buffer memory (not battery backed) for data communication with the CPU.

The buffer memory assignment and data maps are indicated below.

3.7.1 Buffer memory assignment

The following figure shows the buffer memory assignment.

Address(Decimal)		Default Value	Read	Write	Reference
0	A-D conversion enable/disable	00FFH(All channels are set to set to"enable".)	Enabled	Enabled	Section3.7.2
1	Writing data error code	0(All channels)	Enabled	Disabled	Section3.7.5
2	Average processing specification	0(sampling processing specified for all channels)	Enabled	Enabled	Section3.7.3
3 to 9	Unusable		Disabled	Disabled	
10	CH1 Average time, count	0	Enabled	Enabled	Section3.7.3
11	CH2 Average time, count				
12	CH3 Average time, count				
13	CH4 Average time, count				
14	CH5 Average time, count				
15	CH6 Average time, count				
16	CH7 Average time, count				
17	CH8 Average time, count				
18 to 19	Unusable		Disabled	Disabled	
20	CH1 Average time, count	0	Enabled	Disabled	Section3.7.4
21	CH2 Average time, count				
22	CH3 Average time, count				
23	CH4 Average time, count				
24	CH5 Average time, count				
25	CH6 Average time, count				
26	CH7 Average time, count				
27	CH8 Average time, count				
28	A-D conversion completed flag	0	Enabled	Enabled	Section3.7.6
29	Unusable		Disabled	Disabled	

Fig.3.5 Buffer Memory Assignment

POINT

Do not write values from the PLC CPU to any write enabled area in the buffer memory. It will result in an error unless the written values are identical. The "RUN" LED of the A1S68AD will flash, the error flag (X2) will be set, and an error code, which indicates that a value has been written to a write enabled area, will be stored in the error code area in the buffer mamory.

In such a case, the A1S68AD will write the original data over the written data and continue processing.

3.7.2 Setting of A-D conversion-enable/disable

A-D conversion-enable/disable for each channel of A1S68AD can be set at address 0 of the buffer memory by writing "1" (enable) or "0" (disable) by the channel.

The sampling period can be shortened by setting an unused channel to conversion disable.

(Default: All channels A-D conversion enabled)

Example:

Sampling period when setting only channels 1 and 3 to A-D conversion-enable

$$2 \quad \times \quad 0.5 \text{ ms} \quad = \quad 1 \text{ ms}$$

(Number of enable channels) (Conversion speed of one channel)

- (1) Method of setting the conversion-enable/disable
Set the conversion-enable/disable for every channel.

	b15 to b8	b7	b6	b5	b4	b3	b2	b1	b0
Address 0	—	CH8	CH7	CH6	CH5	CH4	CH3	CH2	CH1

Ignored.

Specify channels

- 1 : A-D conversion enable
- 0 : A-D conversion disable

- (2) Processing in the A1S68AD when setting conversion enabled/disabled

- (a) Processing when the A-D conversion setting is switched from disabled to enabled

After the A-D conversion READY flag (X1) has been reset, sampling of the enabled channels begins. The A-D conversion READY flag and the A-D conversion completed flag for the corresponding channels are set as soon as one cycle of sampling processing/averaging processing is completed.

Valid digital output values are stored in the buffer memory just before these flags are set.

- (b) Processing when the A-D conversion setting is switched from enabled to disabled

When averaging processing is specified, all data within the work area for averaging processing is initialized.

This means that processing will start from the first sampling when conversion enabled is specified for the next averaging processing.

Although the A-D conversion completed flag for the corresponding channels is reset immediately, the A-D conversion READY flag remains unchanged.

The buffer memory retains the digital output values before conversion disabled was specified.

3.7.3 Setting of the sampling process/averaging process

- (1) Method of outputting a digital value of the sampling process and the averaging process

- (a) Sampling process

An analog input value is converted to a digital value, and the digital output value is stored in a buffer memory.

The storage time for a digital output value that the sampling process was executed on in the buffer memory depends on the number of A-D conversion-enabled channels.

Processing time =
$$\frac{(\text{number of A-D conversion-enabled channels}) \times 0.5 \text{ (ms)}}{\text{Maximum conversion speed}}$$

Example)

When channels 1, 2 and 3 are set to conversion-enable:

$$3 \times 0.5 = 1.5 \text{ (ms)}$$

- (b) Averaging process

A1S68AD executes the A-D conversion for a channel that was specified for averaging process by a PLC CPU for the set number of times of set time. The total values except a maximum value and a minimum value are averaged and the stored in the buffer memory.

However, when the processing number of times is no more that two, the sampling process is executed. Data for averaging processing is initialized when the A-D conversion setting is switched from enabled to disabled.

- 1) When the averaging process by time is specified

The setting time is set in 1ms unit .

The number of processing events within the preset time depends on the number of channels for which A-D conversion is enabled.

Processing time =
$$\frac{\text{Setting time}}{(\text{number of A-D conversion-enabled channels}) \times 1 \text{ (ms)}} \times \frac{1}{\text{Maximum conversion speed}}$$

Example)

When the number of times of A-D conversion-enabled channels is 4 and the setting time is 8000 msec

$$8000 \div (4 \times 1) = 2000 \text{ (time)}$$

2) When the number of times for the averaging process is specified

The time in which the average is stored to the buffer memory follows the number of A-D conversion-enabled channels.

$$\text{Processing time} = (\text{the setting number of times}) \times (\text{A-D conversion-enabled channel}) \times 1 \text{ (ms)}$$

└──────────┘
Maximum conversion speed

Example)

When example channels 1, 2, 3 and 4 are set to A-D conversion-enable, and the setting number of times is set to 50 times

$$50 \times 4 \times 1 = 200 \text{ (ms)}$$

(2) Specifying the averaging process and selecting time/number of times

(a) When the power supply is turned ON, and the A1S68AD A-D conversion READY signal turns ON, all of the channels are specified for the sampling process.

(b) When sampling processing or averaging processing is specified, and to perform averaging processing, specify the average time or average count.

	b15	b14	b13	b12	b11	b10	b9	b8	b7	b6	b5	b4	b3	b2	b1	b0
Address 2	CH8	CH7	CH6	CH5	CH4	CH3	CH2	CH1	CH8	CH7	CH6	CH5	CH4	CH3	CH2	CH1

Specify the channel in which the averaging process is to be executed.

- 1: Averaging process
- 0: Sampling process

Specify the time/number of times.

- 1: Time averaging process
- 0: Number of times

POINTS

- (1) When the averaging process is specified, the number of times or time for the averaging process should be set beforehand.
- (2) When the averaging process is not specified, despite the specification of the time/number of times, sample processing will be executed.

(3) Specifying the average time and the average number of times

(a) Average time or the average number of times is written in the address that corresponds to the channel of the buffer memory addresses 10 to 17 for every channel that the averaging process was specified.

Average time when a power supply is turned ON and the average number of times is set to 0.

(b) The allowable setting range is as follows.

Averaging process specifying the number of times: 1 to 20000 times

Averaging process by specifying time: 4 to 10000 ms

POINT

When a value is set and written outside the above range, a setting error occurs, and the buffer memory is not rewritten.

The A1S68AD then completes the A-D conversion processing according to the average time and the number of times before a setting error occurs.

3.7.4 Digital output value

(1) Digitally converted values are stored for each channel in buffer memory addresses 20 to 27.

The table below shows the digital output values for each input range:

Input Range	Resolution	Digital Output Value
0 to 10 V	2.5 mV	0 to 4000
-10 to 10 V	5.0 mV	-2000 to 2000
0 to 5 V	1.25 mV	0 to 4000
1 to 5 V	1.0 mV	0 to 4000
0 to 20 mA	5.0 μ A	0 to 4000
4 to 20 mA	4.0 μ A	0 to 4000

(2) The digital output value (-2000 to 4000) is expressed by 16-bit coded binary.

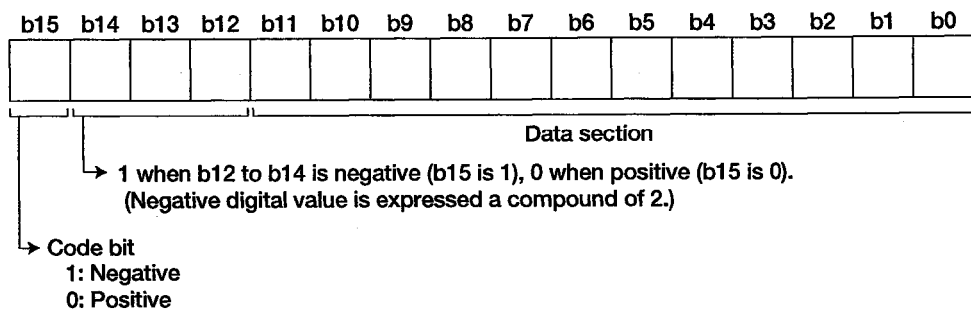

3.7.5 Writing data error code

(1) The A1S68AD checks the preset range of the average time of count written from the PLC CPU, and whether data has been written to a write disabled area.

If the setting is out of the range or data is written to a write disabled area, the error flag (X2) will be set, and the corresponding error code will be stored as a 16-bit binary value at buffer memory address 1.

In such a case, the A1S68AD will write the original data over the written data and continue processing. For details of error codes, refer to Section 6.1.

- (2) When several errors occur, the error code that occurred at first is stored in A1S68AD, and any errors after that are not stored.
- (3) The error code is reset by turning ON Y12 with a sequence program.
- (4) When the error is reset, the error flag (X2) will be reset, and the error code stored in the buffer memory will be cleared to 0. At the same time, the "RUN" LED will stop flashing and come on.

3.7.6 A-D conversion completed flag

- (1) When after turning ON a power supply and an A-D conversion READY signal (X1) turns ON, channels 1 to 8 have already completed all of the A-D conversion. Therefore, 00FF_H is stored in the buffer memory.
- (2) Only when the A-D conversion-enable/disable setting (address 0) is changed, the A-D conversion completed flag processing after turning on a power supply is done one time.

- When A-D conversion-disable is switched to enable

When the averaging processing is specified, the averaging process for the average number of times or average time is completed, and a flag is set to 1 after storing a digital value translated from an analog value in the buffer memory.

- When A-D conversion-enable is switched to disable

The A-D conversion completed flag of a corresponding channel is set to 0.

- (3) There is an A-D conversion-completed flag classified by a channel.

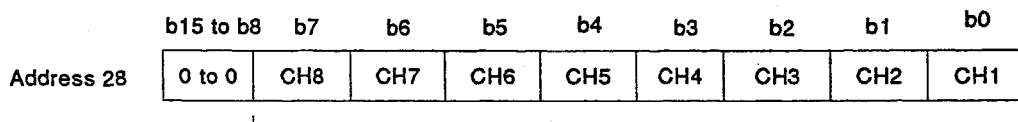

A-D Conversion completion flag
 1: A/D conversion completion
 0: A/D conversion uncompletion

- (4) An A-D conversion-completed flag can be used as an interlock to read a digital value of a channel that the averaging process is done.

4. PRE-OPERATION SETTINGS AND PROCEDURES

4.1 Handling Instructions

The following explains the handling instructions for the A1S68AD.

- (1) Since a case of the AIS68AD and its terminal block are made of resin, do not let the module fall or give a strong.
- (2) Do not remove the printed circuit boards from their housing. Otherwise, it may cause failnre.
- (3) Make sure that no conductive debris can enter the module. Make sure that any debris is removed from the module. Guard particularly against cut off wires.
- (4) Tighten the terminal screws and mounting screws as specified below:

Screw	Tightening Torque Range N·cm
Module fixing screw (M4 screw)	78 to 118
Terminal block installation screw (M3.5 screw)	59 to 88
Terminal block installation screw (M4 screw)	78 to 118

- (5) To install a module to the base unit, insert the module fixing hook into the module fixing hole on the base unit and tighten the module fixing screw. To remove a module, loosen the module fixing screw, and pull the module fixing hook out of the module fixing hole.

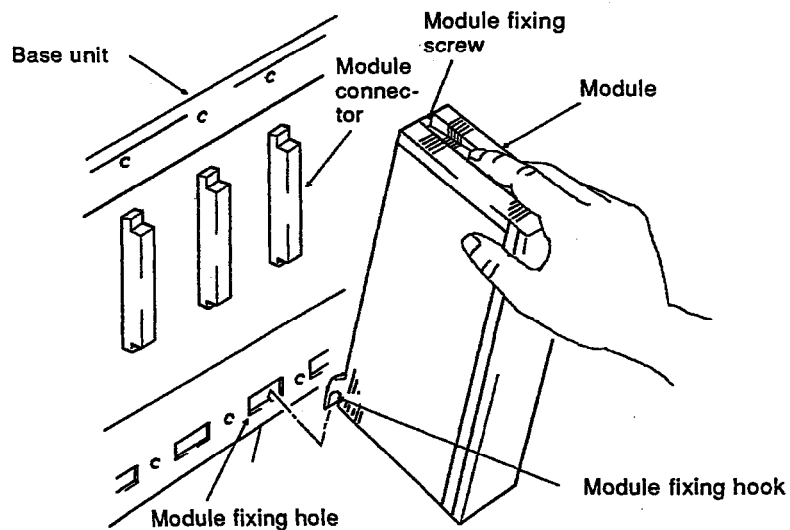

4. PRE-OPERATION SETTINGS AND PROCEDURES

MELSEC-A

4.2 Names and settings of each section

The following gives the Names and settings of each section for each part of the A1S68AD

A1S68AD
RUN O ← (1)

No.	Name and Appearance	Description																										
(1)	RUN LED	Displays the operation status of the A1S68AD. On : Normal operation Flash : Write disabled error or average time/count setting error Off : 5 V power cut or watchdog timer error																										
	RUN ○																											
(2)	Input range selector switch SW1	Used to set the input range for each channel. (Factory default: 0 to 10V) The DIP switch numbers 1 to 8 correspond to the channel numbers. SW1 to SW3 																										
(3)	Input range selector switch SW2	Setting of CH1 <table border="1" style="width: 100%; border-collapse: collapse; text-align: center;"> <thead> <tr> <th>Input Range</th> <th>SW 1-1</th> <th>SW 2-1</th> <th>SW 3-1</th> </tr> </thead> <tbody> <tr> <td>-10 to +10V</td> <td>OFF</td> <td rowspan="2">OFF</td> <td rowspan="3">OFF</td> </tr> <tr> <td>0 to 10 V</td> <td>ON</td> </tr> <tr> <td>0 to 5 V</td> <td>OFF</td> <td rowspan="2">ON</td> </tr> <tr> <td>1 to 5 V</td> <td>ON</td> </tr> <tr> <td>0 to 20mA</td> <td>OFF</td> <td rowspan="2">ON</td> <td rowspan="3">ON</td> </tr> <tr> <td>4 to 20mA</td> <td>ON</td> </tr> <tr> <td>Setting disabled</td> <td>OFF</td> <td rowspan="2">OFF</td> </tr> <tr> <td>Setting disabled</td> <td>ON</td> </tr> </tbody> </table>	Input Range	SW 1-1	SW 2-1	SW 3-1	-10 to +10V	OFF	OFF	OFF	0 to 10 V	ON	0 to 5 V	OFF	ON	1 to 5 V	ON	0 to 20mA	OFF	ON	ON	4 to 20mA	ON	Setting disabled	OFF	OFF	Setting disabled	ON
	Input Range		SW 1-1	SW 2-1	SW 3-1																							
-10 to +10V	OFF	OFF	OFF																									
0 to 10 V	ON																											
0 to 5 V	OFF	ON																										
1 to 5 V	ON																											
0 to 20mA	OFF	ON	ON																									
4 to 20mA	ON																											
Setting disabled	OFF	OFF																										
Setting disabled	ON																											
(4)	Input range selector switch SW3	Set CH2 to CH8 in the same manner.																										

Caution: Applying a voltage input when a current input range is selected may cause a failure.

4.3 Wiring

This section explains the wiring instructions and gives a connection example of a module.

4.3.1 Wiring instructions

Protect the external wiring against noise (extraneous signals) with the following precautions:

- (1) Separate AC and A1S68AD external input signal wiring that is not affected by a surge of alternating current and induction.
- (2) Keep the external wiring at least 10 cm away from the main circuit, high-voltage wires and load carrying wires not originating from the PLC. Otherwise, the external wiring will be affected by noise, surge or induction.
- (3) Where applicable, ground the shielding of all the wires to a common ground point.

4.3.2 Connection example of module

- (1) Voltage input
Signal source 0 to ± 10 V

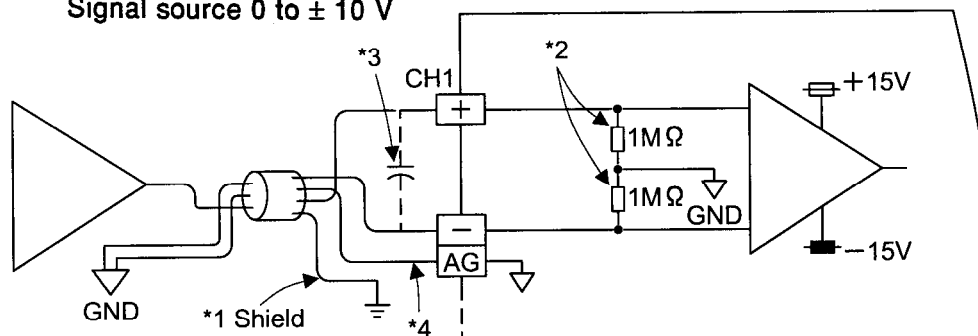

- (2) Current input
Signal source 0 to + 20 mA

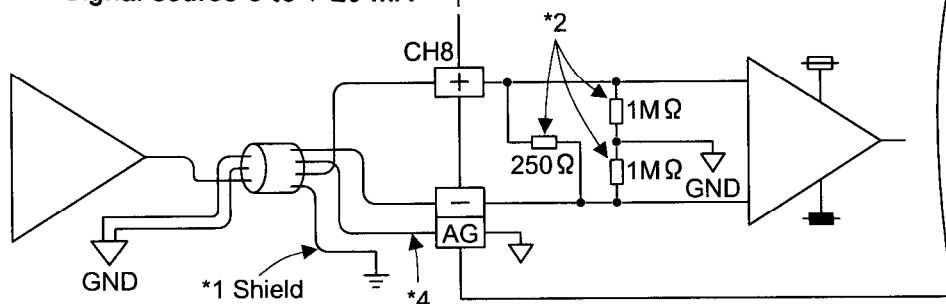

*1: Use two-core shielded wiring (twisted)

*2: Indicates the input resistance of the A1S68AD.
(For voltage input, turn off the 250 Ω resistor with the DIP switch.)

*3: If either noise or ripple is generated by the external wiring, connect a 0.1 to 0.47 μ F (25V or more voltage resistance parts) capacitor to the input terminal of the external device.

*4: AG is the GND terminal of the analog circuit. Connecting it to the GND terminal of an external device is not mandatory, but a higher level of accuracy may be obtained if it is connected.

There is (-10 to +10V input range for 3 channels or more and when the common for the external equipment that is connected to these channels is shared, always connect the AG terminal and the shared common for the external equipment. (Refer to figure below)

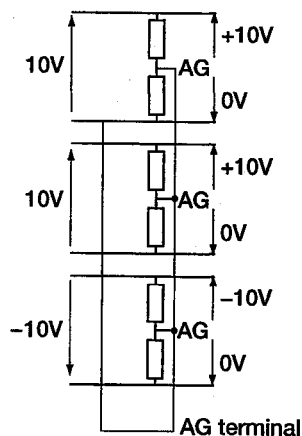
**Point**

When the current input is selected, do not connect the sink type output device and the source output device together. If this happens, normal A/D conversion value cannot be stored.

4.4 Check and Maintenance

For ideal running conditions, follow the check items described in the CPU module User's Manual.

5. PROGRAMMING

This section explains the programming procedure, a basic program, and a read/write programming example when using the A1S68AD.

See to Section 3.7 for the buffer memory and the ACPU Programming Manual for the programming instruction details.

When diverting any of the program examples introduced in this chapter to the actual system, fully verify that there are no problems in the controllability of the target system.

5.1 Programming Procedure

When creating a program to execute the A-D conversion of A1S68AD use the following procedure.

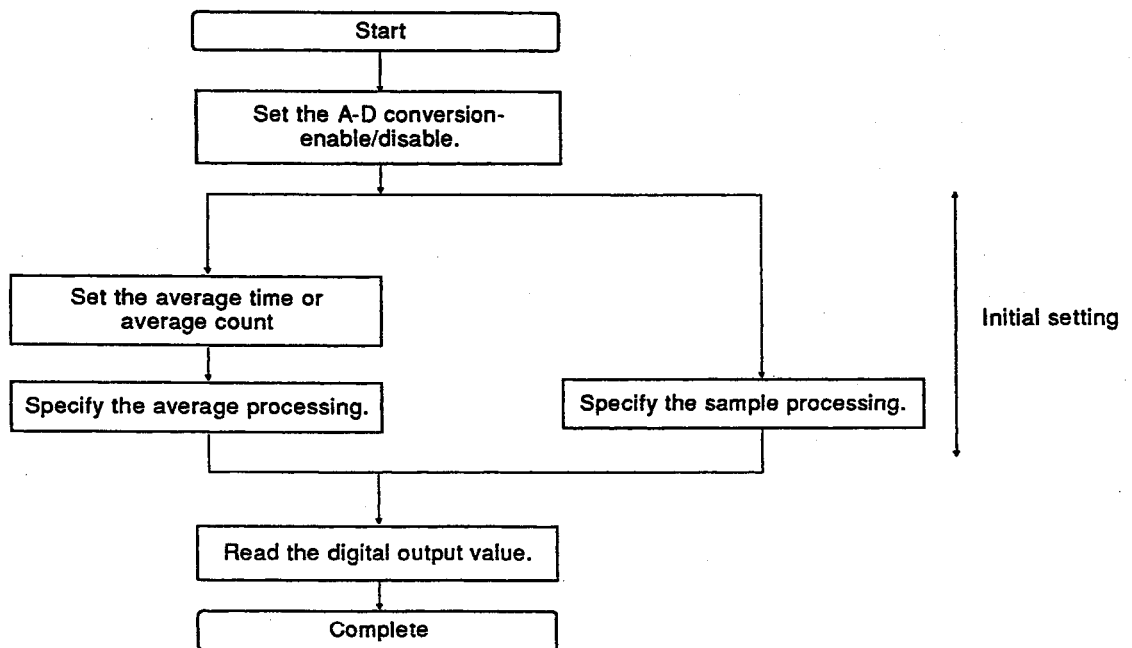

Point

During each of the processes of the special function module, access from the PLC CPU will have priority.

Accordingly, if frequent access to the buffer memory of the special function module made from the PLC CPU, it will not only extend the scan time of the PLC CPU, delays in each of the processes of the special function module will occur.

Only use the FROM/TO and other such commands to access the buffer memory from the PLC CPU when necessary.

5.2 Basic Program for Read/Write

(1) Read from A1S68AD ... FROM, FROMP, DFRO, and DFROP instruction

Format

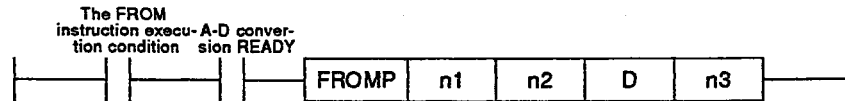

Symbol	Description	Device that Can be Used
n1	The first two (2) digits when the head I/O number is allocated to A1S68AD in three (3) digits of hexadecimal	K, H
n2	Head address of the buffer memory in which data is stored	K, H
D	Head number of the device in which data is stored	T, C, D, W, R
n3	Number of words of read data	K, H

Example

When the A1S68AD is allocated to I/O X130 to 14F and the Y130 to 14F, the data is read from address 10 of the buffer memory to one (1) word D0.

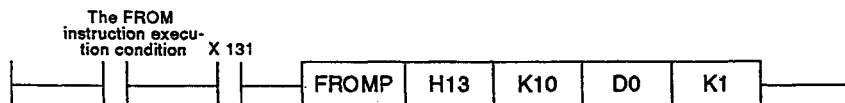

(2) Writing to A1S68AD ... TO, TOP, DTO, and DTO instruction

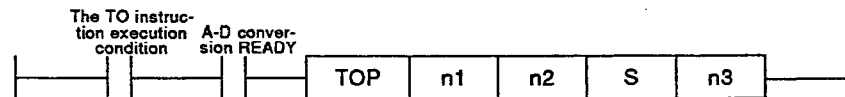

Format

Symbol	Description	Device that Can be Used
n1	The first two (2) digits when the head I/O number is allocated to A1S68AD in three (3) digits of hexadecimal	K, H
n2	Head address of the buffer memory in which data is stored	K, H
S	Number or constant of a head device in which writing data is stored	T, C, D, W, R, K, H
n3	Number of words of write data	K, H

Example

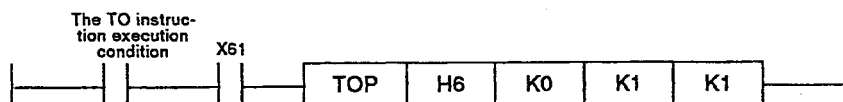

When A1S68AD is allocated to I/O X60 to 7F and Y60 to 7F, 1 is written in address 0 of a buffer memory

5.3 Initial Setting Program and Example of Digital Output Value Read Program

This programming example is used to read the digital output value converted from an analog value with the condition that channels 1 to 3 are used.

Channel 1 is for the sample processing, channel 2 is for the average processing per 50 times, and channel 3 is for the average processing per 1000 ms. When a writing error occurs, an error code is displayed in BCD.

Sample condition of a program

(1) System configuration

Power supply module	A1S CPU	A1S 68 AD	A1S X41 32 points	A1S Y41 32 points		
		X/Y00 to X/Y1F	X20 to X3F	Y40 to Y5F) I/O number	

(2) Initial setting

- (a) A/D conversion-enabled channel 1, 2 and 3 channels
- (b) Average processing channel by count Channel 2, count setting:50 times
- (c) Average processing channel by time Channel 3, time setting:1000 ms

(3) Device to be used by user

- (a) Writing data error reset signalX20
- (b) Digital output value read command input signalX21
- (c) Writing data error occurrence displayY40
- (d) Writing data error code BCD output Y50 to 5B
- (e) Writing data error code storage data registerD0
- (f) A-D conversion completed flag storage device M0 to M2
- (g) Digital output value read data registerD10 to D12

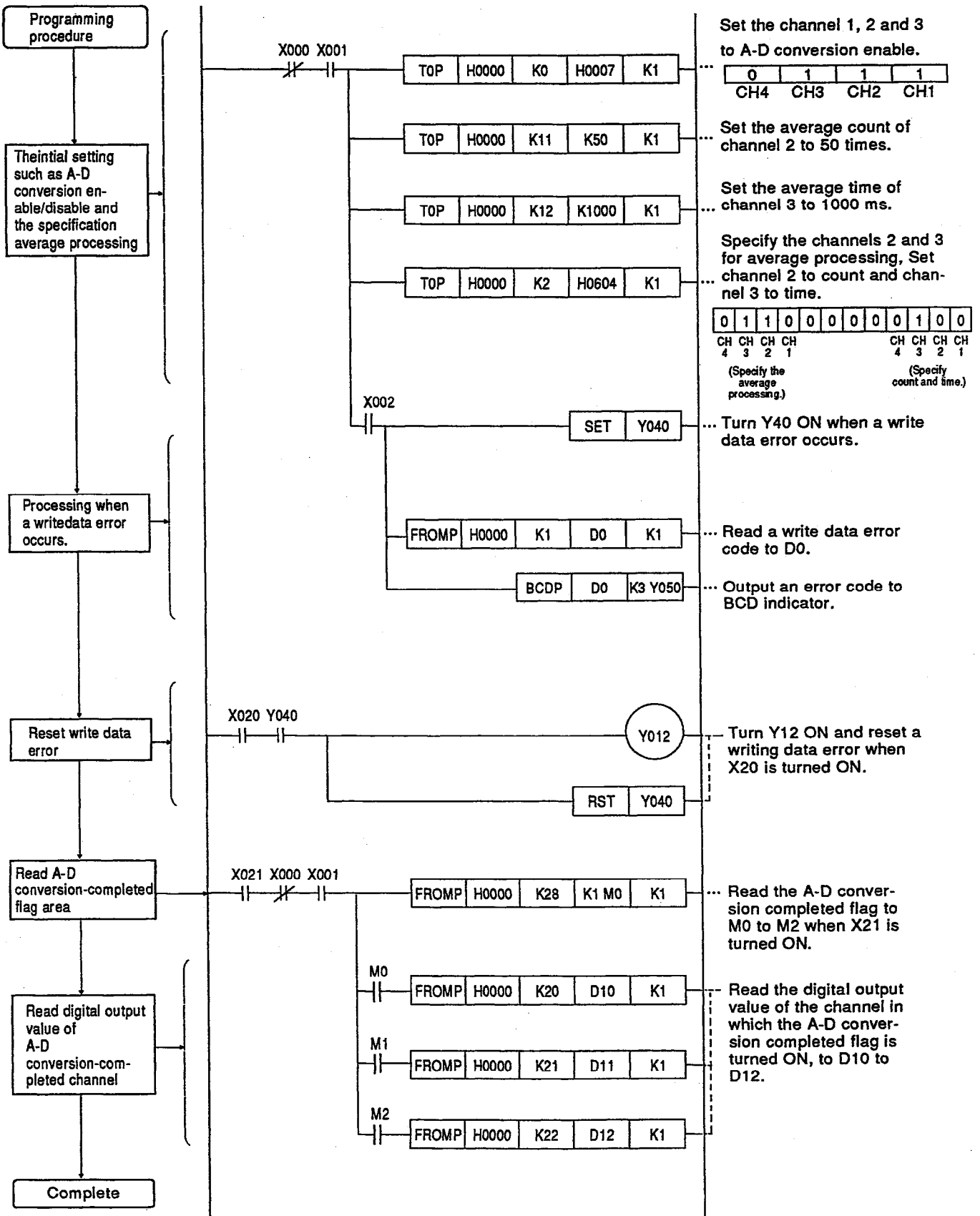

6. TROUBLESHOOTING

Assorted problem conditions and a troubleshooting guide for the A1S68AD are described below.

6.1 Error Code List

When data is written to an A1S68AD from a PLC CPU or an error occurs by reading data (RUN LED of A1S68AD flashes), the following error codes are stored in address 1 of the A1S68AD buffer memory.

Table 6.1 Error Code List (Detected with A1S68AD)

Error Code	Cause	Corrective Action
102	Data was written to the read-only area.	Modify the specified place for the read-only area.
1[] 0	<ul style="list-style-type: none"> A value outside 4 to 10000 ms was set for the average time. [] indicates the channel No. in which an error occurred. 	Set the average time within 4 to 10000 ms.
1[] 5	<ul style="list-style-type: none"> A value outside 1 to 20000 times was set for the average count. [] indicates the channel No. in which an error occurred. 	Set the average count within 1 to 20000 times.

- (1) When several errors occur, the error code that occurred first is stored, and any errors after that are not stored.
- (2) The error code is reset by turning ON Y12 with a sequence program. (See Section 3.6.)

6.2 Troubleshooting

The following explains the simple troubleshooting for A1S68AD. Refer to the CPU Module User's Manual for a PLC CPU module.

6.2.1 When the RUN LED of A1S68AD Flashes

Items to Check	Corrective Actions
Is the data which cannot be executed read/write written to A1S68AD?	Confirm the error cause with the error code list in Section 6.1, and correct the sequence program.

6.2.2 When the RUN LED of A1S68AD goes OFF

Items to Check	Corrective Actions
Is X0 (WDT error) set?	Reset the PLC CPU. If the RUN LED is not turned ON after resetting a PLC CPU, there may be a hardware malfunction in the module. Please contact your local Mitsubishi service representative.

6.2.3 When the digital output value cannot be read

Items to Check	Corrective Actions
Is the RUN LED of A1S68AD flashing or turned OFF?	Follow the procedures in Section 6.2.1 or 6.2.2.
Is the ERROR LED of the CPU is turned ON?	Check the error description according to the CPU User's Manual.
Is the RUN LED of the CPU flashing or turned OFF?	Check the error description listed in the CPU User's Manual.
Is the condition to execute FROM instruction turned ON?	Monitor with a peripheral device such as GPP, and confirm whether it is ON or OFF.
Does the address of the buffer memory specified with a FROM instruction correspond to the address of the digital output value of channel to be read?	Check the sequence program.
Is the channel specified with FROM instruction set to A-D conversion enable?	Read the buffer memory address 0 and verify whether it is set to conversion enable or disable.
Is the conversion completed in the channel specified with FROM instruction ?	Read the buffer memory address 28 and verify the conversion completed flag.
Is the analog input signal line disconnected, or does an error occur?	Confirm the error by visually checking or conduction checking the signal line.
Disconnect the analog input wire of A1S68AD, and apply the test voltage (Stabilized power supply or battery) to the terminal of this module to measure the digital output value.	If the digital output value is normal with an A1S68AD, the module is affected by noise with external wiring. Therefore, check the wiring and grounding method.

APPENDICES

APPENDIX 1 COMPARISON OF PERFORMANCE BETWEEN A1S68AD AND A1S64AD

Table APP-1 Comparison of Performance

Item	Specification			
	A1S68AD		A1S64AD	
Analog input	Voltage: 0 to ±10 VDC(input resistance: 1MΩ) Current: 0 to +20 mA (input resistance: 250Ω) (Can be selected by setting DIP switches.)		Voltage: 0 to ±10 VDC(input resistance: 1 MΩ) Current: 0 to ±20 mA (input resistance: 250 Ω) (Can be selected by using input terminals.)	
Digital output	16-bit signed binary			
I/O characteristic	Analog Input Value	Digital Output Value (Input Range: -10 to 10 V)	Analog Input Value	Digital Output Value Gain: 5 VResolution: 1/12000
	+10V +5V 0V -5V -10V	+2000 +1000 0 -1000 -2000	+10V +5V 0V -5V -10V	+12000 +6000 0 -6000 -12000
Maximum resolution	Voltage input	1 mV (input range: 1 to 5 V)	Voltage input	0.83 mV (resolution: 1/12000)
	Current input	4 μA (input range: 4 to 20 mA)	Current input	3.33 μA (resolution: 1/12000)
Overall accuracy	Within ±1% (accuracy with respect to the maximum value)			
Maximum conversion speed	0.5 ms/channel		20 ms/channel	
Absolute maximum input	Voltage	±35V	Voltage	±15V
	Current	±30mA	Current	±30mA
Number of analog I/O points	8 channels/module		4 channels/module	
Insulation method	Between input terminal and PC power supply: Photocoupler insulation (Between channels: No insulation)			
Number of occupied I/O points	Special 32 points			
Connection terminal	20-terminal block			
External power supply	Unnecessary			
Applicable wire size	0.75 to 1.5mm ²			
Applicable solderless terminal	R1.25-3, 1.25-YS3, RAV1.25-3, V1.25-YS3A			
Internal current consumption (5VDC)	0.31 A		0.4 A	
Weight	0.27 kg		0.25 kg	

APPENDIX 2 VOLTAGE INPUT CHARACTERISTIC OF HARDWARE VERSION N OR EARLIER

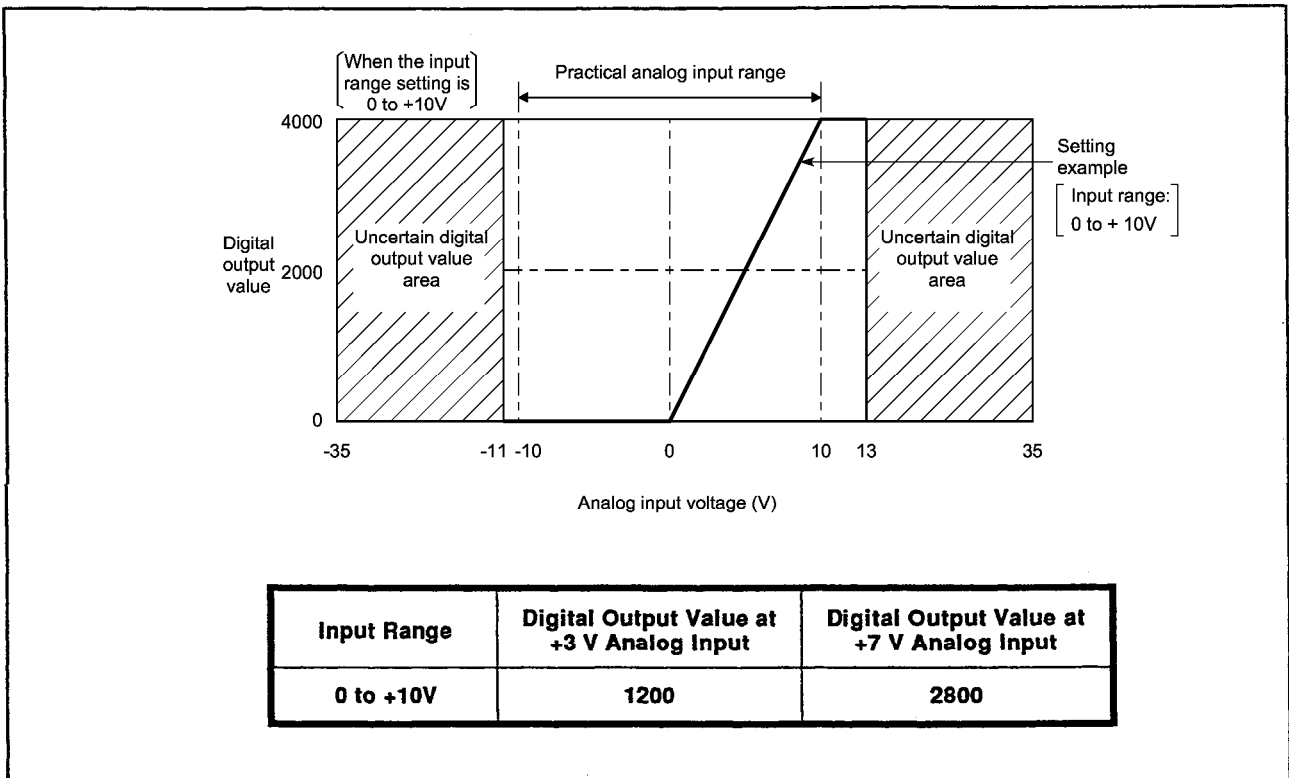
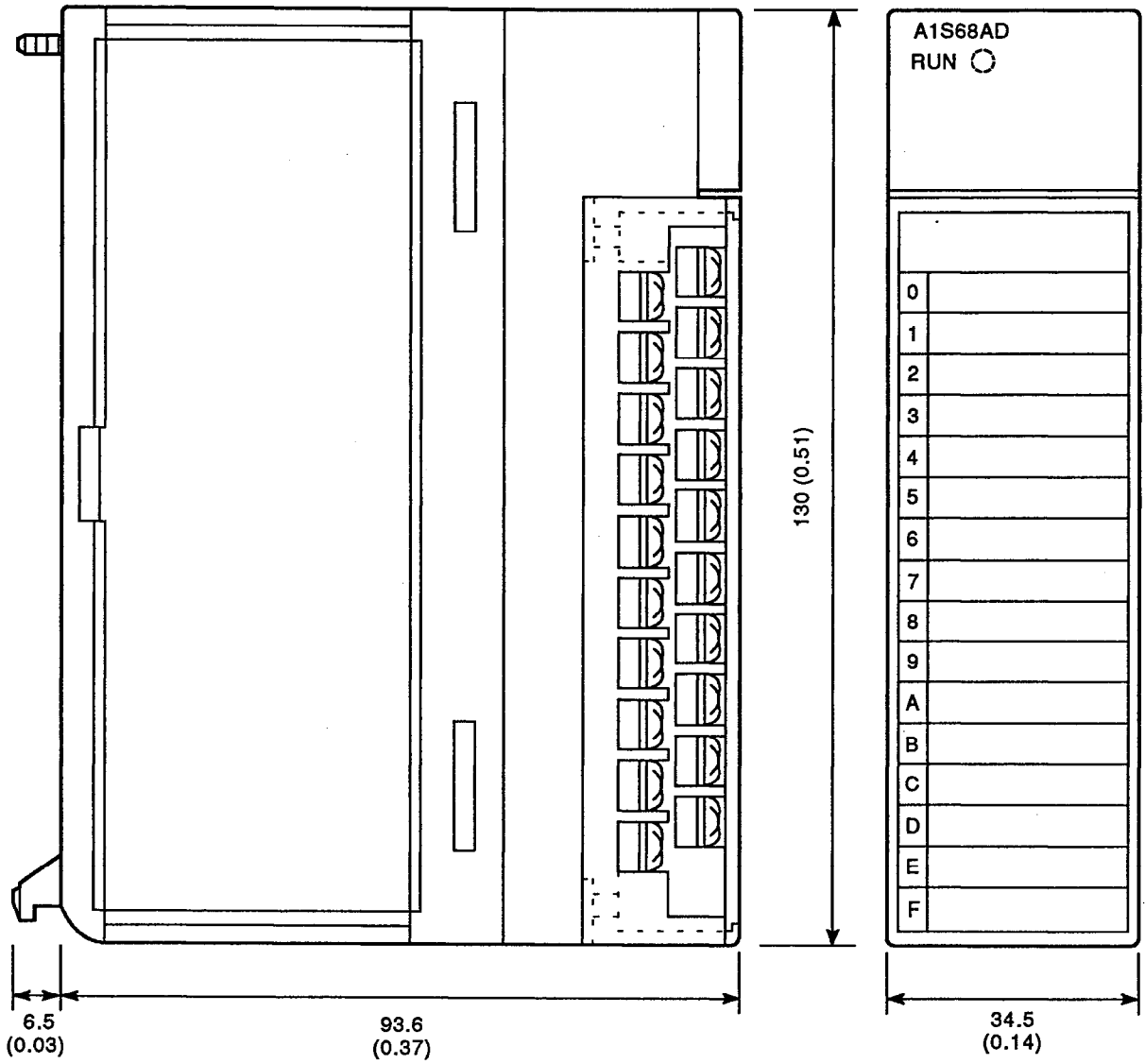

Table APP-1 Voltage input characteristic of hardware version N or earlier

POINTS

- (1) Do not input voltage ± 35 V or more. Otherwise, elements may be broken.
- (2) If an analog input value which, on conversion, will generate a digital output value exceeding the maximum (2000/4000) or minimum (-2000/0) digital output value set for the input range is input at the digital input voltage of within the range -11 to +13V, the digital output value is fixed at the maximum (2000/4000) or minimum (-2000/0) digital value set for the input range.
- (3) When the analog input voltage is outside a range of -11V to +13V, the digital output value cannot be assured.

APPENDIX 3 OUTSIDE DIMENSION



Unit:mm (inch)

MEMO

WARRANTY

Please confirm the following product warranty details before using this product.

1. Gratis Warranty Term and Gratis Warranty Range

If any faults or defects (hereinafter "Failure") found to be the responsibility of Mitsubishi occurs during use of the product within the gratis warranty term, the product shall be repaired at no cost via the sales representative or Mitsubishi Service Company.

However, if repairs are required onsite at domestic or overseas location, expenses to send an engineer will be solely at the customer's discretion. Mitsubishi shall not be held responsible for any re-commissioning, maintenance, or testing on-site that involves replacement of the failed module.

[Gratis Warranty Term]

The gratis warranty term of the product shall be for one year after the date of purchase or delivery to a designated place.

Note that after manufacture and shipment from Mitsubishi, the maximum distribution period shall be six (6) months, and the longest gratis warranty term after manufacturing shall be eighteen (18) months. The gratis warranty term of repair parts shall not exceed the gratis warranty term before repairs.

[Gratis Warranty Range]

- (1) The range shall be limited to normal use within the usage state, usage methods and usage environment, etc., which follow the conditions and precautions, etc., given in the instruction manual, user's manual and caution labels on the product.
- (2) Even within the gratis warranty term, repairs shall be charged for in the following cases.
 1. Failure occurring from inappropriate storage or handling, carelessness or negligence by the user. Failure caused by the user's hardware or software design.
 2. Failure caused by unapproved modifications, etc., to the product by the user.
 3. When the Mitsubishi product is assembled into a user's device, Failure that could have been avoided if functions or structures, judged as necessary in the legal safety measures the user's device is subject to or as necessary by industry standards, had been provided.
 4. Failure that could have been avoided if consumable parts (battery, backlight, fuse, etc.) designated in the instruction manual had been correctly serviced or replaced.
 5. Failure caused by external irresistible forces such as fires or abnormal voltages, and Failure caused by force majeure such as earthquakes, lightning, wind and water damage.
 6. Failure caused by reasons unpredictable by scientific technology standards at time of shipment from Mitsubishi.
 7. Any other failure found not to be the responsibility of Mitsubishi or that admitted not to be so by the user.

2. Onerous repair term after discontinuation of production

- (1) Mitsubishi shall accept onerous product repairs for seven (7) years after production of the product is discontinued. Discontinuation of production shall be notified with Mitsubishi Technical Bulletins, etc.
- (2) Product supply (including repair parts) is not available after production is discontinued.

3. Overseas service

Overseas, repairs shall be accepted by Mitsubishi's local overseas FA Center. Note that the repair conditions at each FA Center may differ.

4. Exclusion of loss in opportunity and secondary loss from warranty liability

Regardless of the gratis warranty term, Mitsubishi shall not be liable for compensation of damages caused by any cause found not to be the responsibility of Mitsubishi, loss in opportunity, lost profits incurred to the user by Failures of Mitsubishi products, special damages and secondary damages whether foreseeable or not, compensation for accidents, and compensation for damages to products other than Mitsubishi products, replacement by the user, maintenance of on-site equipment, start-up test run and other tasks.

5. Changes in product specifications

The specifications given in the catalogs, manuals or technical documents are subject to change without prior notice.

6. Product application

- (1) In using the Mitsubishi MELSEC programmable logic controller, the usage conditions shall be that the application will not lead to a major accident even if any problem or fault should occur in the programmable logic controller device, and that backup and fail-safe functions are systematically provided outside of the device for any problem or fault.
- (2) The Mitsubishi programmable logic controller has been designed and manufactured for applications in general industries, etc. Thus, applications in which the public could be affected such as in nuclear power plants and other power plants operated by respective power companies, and applications in which a special quality assurance system is required, such as for Railway companies or Public service purposes shall be excluded from the programmable logic controller applications.

In addition, applications in which human life or property that could be greatly affected, such as in aircraft, medical applications, incineration and fuel devices, manned transportation, equipment for recreation and amusement, and safety devices, shall also be excluded from the programmable logic controller range of applications.

However, in certain cases, some applications may be possible, providing the user consults their local Mitsubishi representative outlining the special requirements of the project, and providing that all parties concerned agree to the special circumstances, solely at the users discretion.

Analog-Digital Converter Module Type A1S68AD

User's Manual

MODEL	A1S68AD-U-E
MODEL CODE	13J757
IB(NA)-66576-D(0406)MEE	

 **MITSUBISHI ELECTRIC CORPORATION**

HEAD OFFICE : 1-8-12, OFFICE TOWER Z 14F HARUMI CHUO-KU 104-6212, JAPAN
NAGOYA WORKS : 1-14 , YADA-MINAMI 5-CHOME , HIGASHI-KU, NAGOYA , JAPAN

When exported from Japan, this manual does not require application to the Ministry of Economy, Trade and Industry for service transaction permission.

Specifications subject to change without notice.